

ARES

IT ISTRUZIONI DI MONTAGGIO
GB ASSEMBLING INSTRUCTIONS
FR NOTICE DE MONTAGE
SLO NAVODILA ZA MONTAŽO
SRB UPUTSTVO ZA MONTAŽU

D MONTAGEANLEITUNG
ES INSTRUCCIONES DE MONTAJE
P INSTRUÇÕES DE MONTAGEM
HR UPUTE ZA MONTAZU
RO FOAIE CU INSTRUCȚIUNI
BG ИНСТРУКЦИИ ЗА СГЛОБЯВАНЕ

COD.0WGDTI506PDKZD

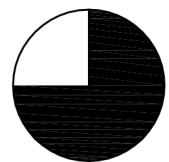
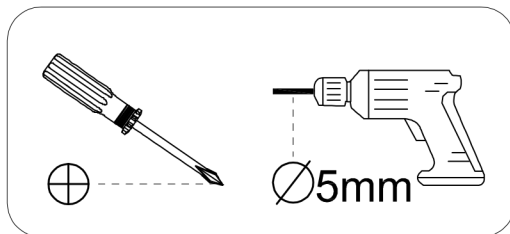
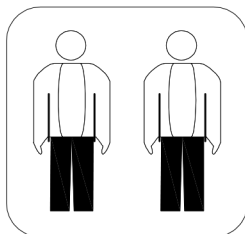

120 MIN

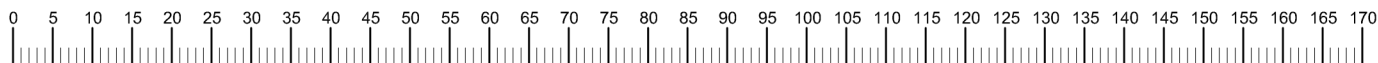
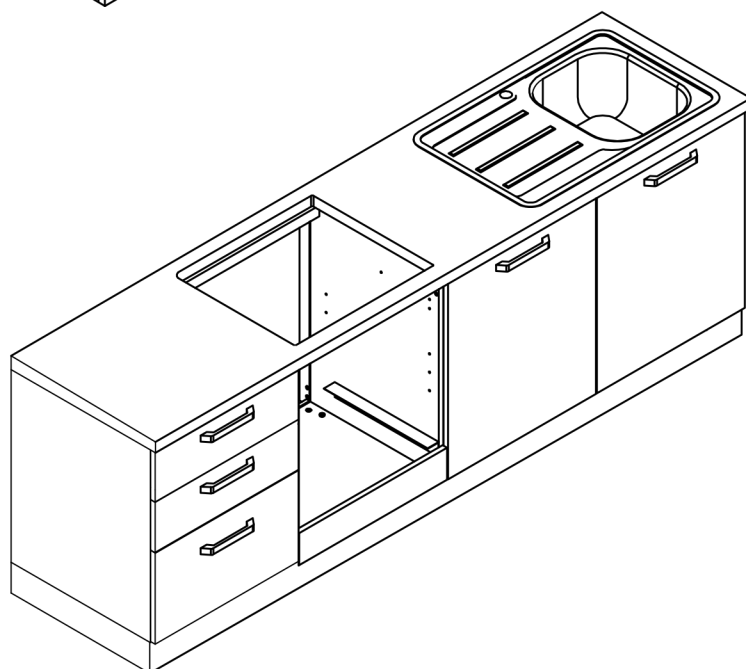
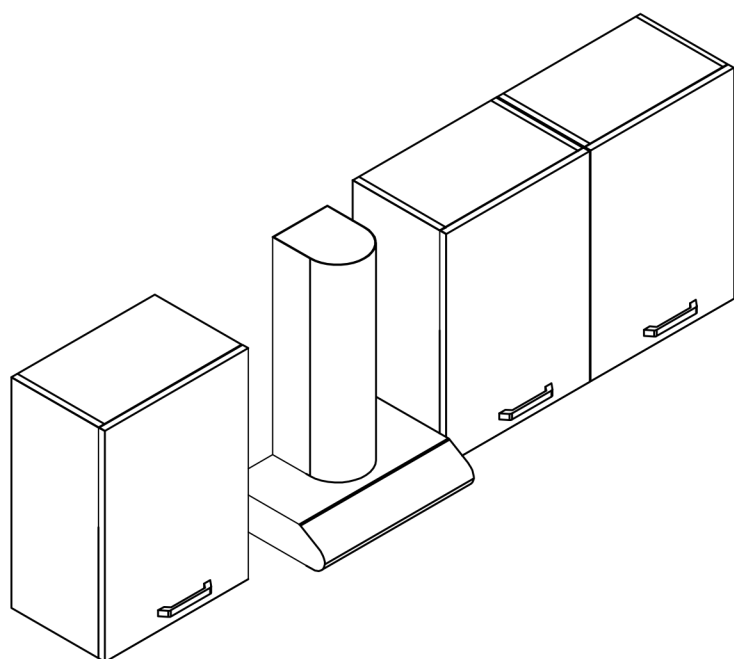

Française – Suisse

CONSEILS DE MONTAGE

1. Bien étudier la notice de montage;
2. Repérez les pièces constituant votre meuble;
3. Regroupez et contrôlez la quincaillerie;
4. Munissez-vous de l'outillage nécessaire;
5. Aménagez-vous une zone de montage;
6. Procédez au montage.

CONSEILS D'ENTRETIEN

1. Dépoussiérez soigneusement;
2. Humecter un chiffon doux et propre d'eau légèrement savonneuse (ou détergent)



Ne jamais forcer les assemblages
Resserrez les vis après quelques temps d'usage
Garder votre notice de montage
Si une pièce devait a manquer, le plus simple est de contacter votre magasin directement
Le poids maximum autorisé sur les boîtes de tiroir est de 10 kg

Ne jamais utiliser de produits abrasifs: poudre, laine d'acier, solvants

English

ASSEMBLING ADVICE

1. Study careful the assembly instructions;
2. Characterize pieces that form the furniture;
3. Group and control the ironware;
4. Take the necessary tools for the assembly;
5. Prepare an assembly zone;
6. Proceed with the assembly.

MAINTENANCE ADVICE

1. Dust accurately;
2. Damp a cleaned and soft cloth with water and little detergent.



Never force the assemblages
Screw the screws after a long period
Conserve the assembly instructions
If one or more pieces are missing, please contact the store
Maximum weight allowed on drawer boxes is 10kg.

Do not use abrasive products: powder, steel wool, solvents

Italiano – Svizzera

CONSIGLI DI MONTAGGIO

1. Studiare bene le istruzioni di montaggio;
2. Controllare che tutti i pezzi che costituiscono il mobile siano presenti;
3. Raggruppare e controllare la ferramenta;
4. Munirsi degli utensili necessari al montaggio;
5. Allestire una zona di montaggio;
6. Procedere al montaggio.

CONSIGLI PER LA MANUTENZIONE

1. Spolverare accuratamente;
2. Inumidire con acqua leggermente insaponata uno straccio morbido e pulito.



Non forzare mai gli assemblaggi
Stringere le viti dopo un periodo d'uso
Conservare le istruzioni di montaggio
Se un pezzo dovesse mancare o essere rotto, contattare il punto vendita
Il peso massima supportato dai cassetti è di 10kg.

Non utilizzare mai prodotti abrasivi: polvere, lana di acciaio, solventi

Deutsch – Schweiz

MONTAGE ANLEITUNG

1. Die Montageanleitung genau durchlesen;
2. Die Einzelteile des Möbels stück ermitteln;
3. Die Beschläge zusammenlegen und prüfen;
4. Das Notwendige werkzeug zurechtlegen;
5. Einem Montagebereich freimachen;
6. Das Möbels stück zusammenbauen.

PFLEGEHINWEISE

1. Sorgfältig entstauben;
2. Mit einem weichen, sauberen und feuchtem Tuch und leichter selfentauge reinigen



Niemals die Verbindungen zu stark anziehen
Die Schrauben nach Lang Zeit des Gebrauchs erneut festziehen
Die Montageanleitung gut aufbewahren
Wenn ein Teil fehlen, ist Sie das beste Verständigungsmittel mit Ihrem Geschäft
Das maximale Gewicht auf Schubladenkästen erlaubt ist 10 kg

Benutzen Sie keine Scheuermittel wie Pulver, Stahlwolle, Lösungsmittel

Español

CONSEJOS PARA EL MONATJE

1. Estudie atentamente el manual de montaje;
2. Localice las piezas que constituyen su mueble;
3. Reuna y contrle los tornillos;
4. Equipese de las herramientas necesarias;
5. Prepare una zona de montaje;
6. Realice el montaje.

CONSEJOS PARA EL MANTENIMIENTO

1. Despolvorear cuidadosamente;
2. Humedecer un pano suave y limpio con agua ligeramente enjabonada.

Portogues

CONSELHOS DE MONATAGEM

1. Estuda bem as instruções de montagem;
2. Junta as peças que constituem o seu móvel;
3. Reagrupa e controla a quinquilharia;
4. Equipa-se da ferramenta necessária;
5. Cria-se uma zona de montagem;
6. Proceda á montagem.

CONSELHOS DE MONTAGEM

1. Eliminar bem o po;
2. Umedecer um pano suave e limpo con agua e um pouco de sabao.

Hrvatski

SAVJETI ZA MONTAZU

1. Porucite pazljivo upute za montazu;
2. Prekontrolirajte po uputama da li imate sve dielove;
3. Prekontrolirajte da li imate sve vijke, matice i ostale metalne dielove;
4. Osugurajte potreban alat za sastavljanje;
5. Oslobodite odgovarajuci prostor za montiranje;
6. Ukoliko ste provjerili sve gore navedeno mozete zapoceti montazu.

SAVJETI ZA ODRZAVANJE

1. Uklanjanje redivito prasinu i necistoce;
2. Cistite uvijek s mlo vode i blagog deterdzenta te mekom i cistom krpom.

SLOVENŠČINA

NAVODILA ZA MONTAŽO

1. Pozorno preberite navodila za montažo;
2. Določite posamezne dele pohištva;
3. Preverite, ali imate vse vijake, matice in ostale kovinske dele;
4. Pripravite potrebna orodja;
5. Pripravite in počistite prostor, kjer boste pohištvo sestavljali;
6. Sestavite pohištvo.

NAVODILA ZA NEGO

1. Redno brišite prah.
2. Očistite z mehko, čisto in vlažno krpo ter uporabite malo milnice.

 No fuerce nunca en las uniones
Apriete los tornillos despues de cierto tiempo de utilizacion
Conserve su manual de montaje
Si faltara una pieza, seia la manera mas facil de comunicar con la tienda
El peso máximo permitido en las cajas de cajón es de 10 kg

No use nunca productos abrasivos tales como: polvo de limpiar, lana de acero, solventes.

 Nunca esforçar as montagem
Apertar os pafusos após un tempo de utilização
Guardar as instruções de montagem, si faltara alguna pieza, lo mas aconsejable es contactar con la tienda
O peso máximo permitido em caixas de gaveta é de 10 kg

Nunca utilizar productos abrasivos pos, la de aço, solventes

 Prilikom montiranja, nemojte nasilno pokušavati spojiti dielove
Odvijati vijke nakon duzeg stajanja montiranog proizvod
Ukoliko Vam nedostaje koji dio, molimo Vas kontaktirajte trgovinu u kojoj ste namjestaj kupili
Ladica ima nosivost od maksimalnih 10kg

Nemojte koristiti abrazivne krpe, pudere, matalnu vunu ili sredstva koja mogu otopiti površinu namjestaja

 Delov ne zategujte preveč.
Po daljšem času ponovno zategnite vijake.
Navodila za montažo hranite na varnem mestu.
Če kakšen del manjka, kontaktirajte prodajalno, v kateri ste pohištvo kupili.
Predali imajo največjo nosilnost 10 kg.

Ne uporabljajte abrazivnih krp, praškov, jeklene volne ali sredstev, ki lahko raztopijo površino pohištva.



БЪЛГАРСКИ

СЪВЕТ ЗА МОНТАЖ

1. ПРОУЧЕТЕ ВНИМАТЕЛНО ИНСТРУКЦИИТЕ ЗА СГЛОБИКА;
2. ПРОВЕРЕТЕ ДАЛИ ВСИЧКИ ЧАСТИ, КОИТО СЪСТАВЛЯВАТ МЕБЕЛИТЕ ПРИСЪСТВАТ;
3. ПРОВЕРЕТЕ ДАЛИ ИМАТЕ ВСИЧКИ ВИНТОВЕ, ГАЙКИ И ДРИГУ МЕТАЛНИ ЧАСТИ;
4. ОСИГУРЕТЕ НЕОВХОДИМИТЕ ИНСТРУМЕНТИ ЗА СГЛОБИАВАНЕ;
5. ОСВОБОДЕТЕ ПОДХОДЯЩО МЯСТО ЗА МОНТАЖ;
6. ПРОДЪЛЖЕТЕ КЪМ СГЛОБЯВАНЕТО;

СЪВЕТ ЗА ПОДДРЪЖКА

1. ПОЧИСТЕТЕ СТАРАТЕЛНО ОТ ПРАХ;
2. НАВЛАЖНЕТЕ МЕК ЧИСТ ПАРЦАЛ С ЛЕКО САПУНЕНА ВОДА.

!
НИКАКЪВ СЛУЧАЙ НЕ ПРЕНАТЯГАЙТЕ. СЛЕД ДЪЛГО ВРЕМЕ **СТЯГАМ** ОТНОВО ВИНТОВЕТЕ. ПАЗЕТЕ ИНСТРУКЦИИТЕ ЗА СГЛОБИАВАНЕ
АКО НЯКОЯ ЧАСТ ЛИПСВА ИЛИ Е СЧУПЕНА СЪВЪРЖЕТЕ СЕ МАГАЗИНА ОТ КОИТО СТЕ ЗАКУПИЛИ МЕБЕЛИТЕ. МАКСИМАЛНО ТЯЛО ПОДДЪРЖАНО ОТ ЧЕКМЕДЖЕТО Е **10KG**

НЕ ИЗПОЛЗВАЙТЕ АБРАЗИВНИ ПРОДУКТИ: ПРАХ, СТОМАНЕНА ВАТА, РАЗТВОРИТЕЛИ

ROMANIA

SFATURI DE MONTAJ

1. Studiați cu atenție instrucțiunile de asamblare;
2. Verificați dacă toate piesele care compun mobilierul sunt prezente;
3. Grupați și verificați hardware-ul;
4. Echipați-va cu sculele necesare asamblării;
5. Amenajează o zonă de asamblare;
6. Continuați cu asamblarea.

!
Nu forțați niciodată ansamblurile.
Strângeți șuruburile după o perioadă de utilizare.
Păstrați instrucțiunile de asamblare
Dacă o piesă lipsește sau este ruptă, contactați punctul de vânzare.
Greutatea maximă suportată de sertare este de **10 kg.**

SFATURI DE ÎNTREȚINERE

1. Curatați praful bine;
2. Umeziți cu apă ușor săpun o cârpă moale și curată.

Nu utilizați niciodată praf abraziv, lână de sticlă sau solvenți.

SRPSKI

UPUTSTVO ZA MONTAŽU

1. PAŽLJIVO PROČITAJTE UPUTSTVO ZA MONTAŽU;
2. PREKONTROLIŠITE PREMA UPUTSTVU DA LI IMATE SVE POTREBNE DELOVE;
3. PREKONTROLIŠITE DA LI IMATE SVE ŠRAFOVE, MATICE I OSTALE METALNE DELOVE;
4. OSUGURAJTE POTREBAN ALAT ZA SASTAVLJANJE;
5. PRIPREMITE ODGOVARAJUĆI PROSTOR ZA MONTIRANJE;
6. UKOLIKO STE PROVERILI SVE GORE NAVEDENO MOŽETE ZAPOČETI MONTAŽU.

!
PRILIKOM MONTIRANJA NE POKUŠAVATI NASILNO SPAJANJE DELOVA.
NAKON DUŽEG VREMENA KORIŠĆENJA PROIZVODA, ŠRAFOVE PONOVNO PRIČVRSTITI.
UKOLIKO VAM NEDOSTAJE ODREĐENI DEO, MOLIMO VAS DA KONTAKTIRATE PRODAJNI CENTAR GDE STE NAMEŠTAJ KUPILI. FIOKA IMA MASKIMALNU NOSIVOST **10 KG.**

NE KORISTITI ABRAZIVNE KPRE, PUDERE, ČELIČNU VUNU ILI SREDSTVA KOJA MOGU OŠTETITI POVRŠINU NAMEŠTAJA.

SAVETI ZA ODRŽAVANJE

1. UKLANJAJTE REDOVNO PRAŠINU I NEČISTOĆU;
2. ODRŽAVANJE MEKOM I VLAŽNOM KRPOM UZ UPOTREBU BLAGOG DETERDŽENTA.

(IT) ISTRUZIONI DI MONTAGGIO
(GB) ASSEMBLING INSTRUCTIONS
(FR) NOTICE DE MONTAGE
(SLO) NAVODILA ZA MONTAŽO
(SRB) RS UPUTSTVO ZA MONTAŽU

(D) MONTAGEANLEITUNG
(ES) INSTRUCCIONES DE MONTAJE
(P) INSTRUCOES DE MONTAGEM
(HR) UPUTE ZA MONTAZU
(RO) FOAIE CU INSTRUCȚIUNI
(BG) ИНСТРУКЦИИ ЗА СГЛОБЯВАНЕ

IMPORTANTE: Per evitare il ribaltamento accidentale del mobile è obbligatorio il fissaggio a muro. I tasselli necessari per il collegamento mobile/muro, dipendenti dal tipo di muro, non sono compresi. Consultare uno specialista in caso di dubbi.

IMPORTANT: To avoid the accidental tip-over of the furniture, the fixing of the furniture on the wall is mandatory. The needed hardware for the junction wall/furniture, depending of the nature of the wall, is not provided. If any doubt, consult a specialist.

IMPORTANT: Pour éviter le basculement accidentel du meuble, la fixation du meuble au mur est obligatoire. La visserie nécessaire pour la jonction mur/meuble, dépendante de la nature du mur n'est pas fournie. En cas de doute, consulter un spécialiste.

WICHTIG: Um die versehentliche Trübung der Möbel zu vermeiden, ist die Befestigung der Möbel an der Wand obligatorisch. Die benötigte Hardware für die Verteilungswand / Möbel, je nach Art der Wand, ist nicht vorgesehen. Wenn irgendwelche Zweifel, konsultieren Sie einen Spezialisten.

IMPORTANTE: Para evitar el vuelco accidental de los muebles, la fijación de los muebles en la pared es obligatoria. El hardware necesario para la pared / los muebles de la unión, dependiendo de la naturaleza de la pared, no se proporciona. En caso de duda, consulte a un especialista.

IMPORTANTE: Para evitar a queda accidental do mobiliário, a fixação dos móveis na parede é obrigatória. O hardware necessário para a junção parede / móveis, dependendo da natureza da parede, não é fornecido. Em caso de dúvida, consulte um especialista.

VAŽNO: Da bi se izbjeglo slučajno tip-over namještaja, fiksiranje namještaja na zidu je obavezno. Potreban hardver fot na spoj zida / namještaja, ovisno o prirodi zida, nije predviđeno. Ako imate bilo kakve sumnje, konzultirati stručnjaka.

VAŽNO: U CILJU IZBEGAVANJA SLUČAJNOG TIP-OVER NAMEŠTAJA OBAVEZNO JE FIKSIRANJA NAMEŠTAJA NA ZID. NIJE PREDVIĐEN HARDVER FOT NA SPOJU ZIDA/NAMEŠTAJA. U SLUČAJU NEJASNOĆA POTREBNO JE KONSULTOVATI STRUČNO LICE.

OPOZORILO:

Da ne bi pohištva prevrnili, je pritrditev pohištva na steno obvezna.

Deli, potrebni za pritrditev pohištva na steno, ki so odvisni od vrste stene, niso priloženi. Če ste v dvomih, se posvetujte s strokovnjakom.

ВАЖНО:

да избегнете Случайно преобръщане на МЕБЕЛИТЕ ТЕ ТРЯБВА Да бъдат фиксирани към стената Не са включени Дюбелите необходими За връзки мебели стени в зависимост от Вида на СТЕНАТА При съмнения се консултирайте със специалист

IMPORTANT: Pentru a evita rasturnarea accidentala a mobilierului, fixarea pe perete este obligatorie. Mufele necesare pentru racordarea dulap/perete, in functie de tipul de perete, nu sunt incluse. Consultați un specialist dacă aveți dubii.

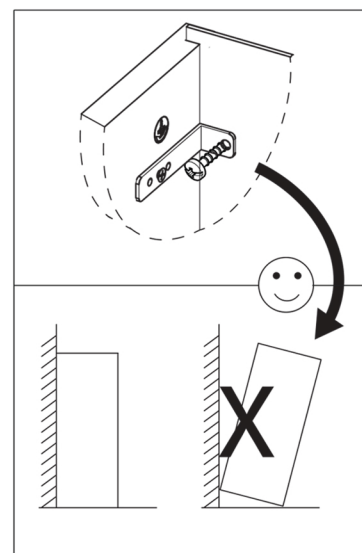

ARES

(IT) ISTRUZIONI DI MONTAGGIO
(GB) ASSEMBLING INSTRUCTIONS
(FR) NOTICE DE MONTAGE
(SLO) NAVODILA ZA MONTAŽO
(SRB) UPUTSTVO ZA MONTAŽU

(D) MONTAGEANLEITUNG
(ES) INSTRUCCIONES DE MONTAJE
(P) INSTRUCIONES DE MONTAGEM
(HR) UPUTE ZA MONTAZU
(RO) FOAIE CU INSTRUCIUNI
(BG) ИНСТРУКЦИИ ЗА СГЛОБЯВАНЕ

	Cod.	Parcel number	Size - mm.	Description	n.
1	8WXXKEX6001	8WXXKEX6001		HOOD	1
2	8WXXLXO791D	8WXXLXO791D		SINK	1
3	2WGD TIBF607PD	2WGD TIBF607PD		OVEN UNIT L.60 H.72	1
4	8WECAPC059XB	8WECAPC059XB		HOB	1

	Cod.	Parcel number	Size - mm.	Wall unit I.60 h.72	n.
5-1	4WXXTI2FI201	2WKTTI6304	720X310X18	LH-RH SIDE	2
5-2	4WXXBI2RI004	2WKTTI6304	562X491X18	SHELF	1
5-3	4WXXKZ7SP604	2WGD KZ6095	596X716X18	DOOR	1
5-4	4WKTTI2BC004	2WKTTI6304	563X309.5X18	TOP/BOTTOM	2
5-5	5MRPA2050	2WKTTI6304	698X578X3	BACK PANEL	1

	Cod.	Parcel number	Size - mm.		n.
6	2WGD TIPS607KZD	2WGD TIPS607KZD		WALL UNIT L.60 H.72	1

	Cod.	Parcel number	Size - mm.		n.
7	4WGDBITPF2464D	2WGDBITPF2464D	2402X600X38	TOP	1

	Cod.	Parcel number	Size - mm.	Cabinet I.60 h.72	n.
8-1	9WXXNC1FA132	2WKTTI6005	563X67X3	JOIN CHAIN	2
8-2	4WXXTI1FI201	2WKTTI6005	720X560X3	LH-RH SIDE	2
8-3	4WKTBI1BA004	2WKTTI6005	563X531X18	BOTTOM	1
8-4	4WXXPD7SP604	2WGD PD6095	596X715X18	DOOR	1
8-5	4WXXBI1RI004	2WKTTI6005	562X491X18	SHELF	1
8-6	5MRBA2010	2WKTTI6005	708X578X18	BACK PANEL	1

	Cod.	Parcel number	Size - mm.	Sink cabinet I.60 h.72	n.
9-1	9WXXNC1FA132	2WKTTI6102	563X67X18	JOIN CHAIN	3
9-2	4WXXTI1FI201	2WKTTI6102	720X560X18	LH-RH SIDE	2
9-3	4WKTBI1BA004	2WKTTI6102	563X531X18	BOTTOM	1
9-4	4WXXPD7SP604	2WGD PD6095	596X715X18	DOORS	1

10	8WXXZAK502	8WXXZAK502		PLINTH	1
11	8WXXGLMX14	8WXXGLMX14		KITCHEN MIXER	1
12	8WECAFO045N	8WECAFO045N		OVEN	1
13	9WXXAPLA601	9WXXAPLA601		UNDER SINK PROTECTOR	1
14	2WGD TIBCC607PD	2WGD TIBCC607PD		CABINET L.60 H.72	1

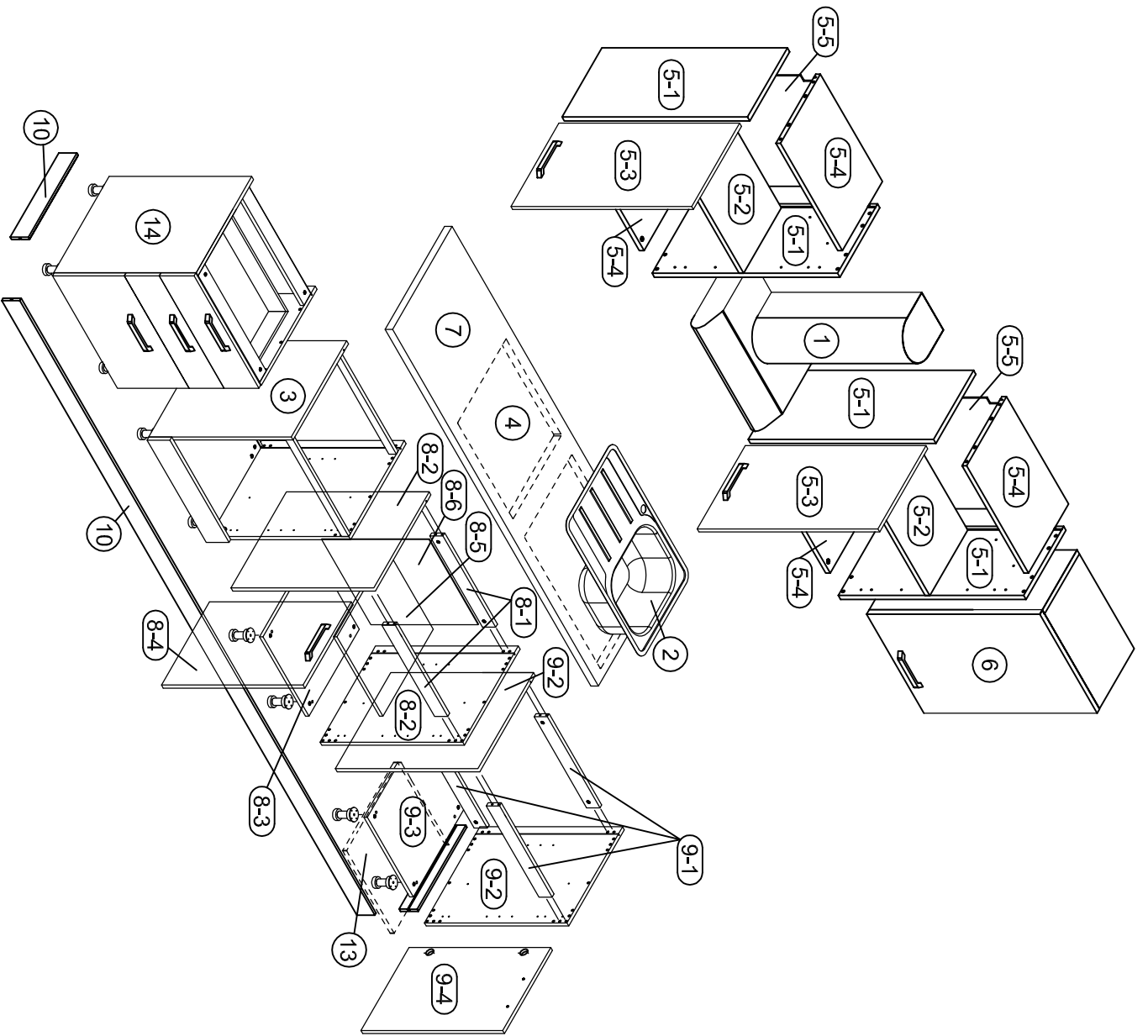

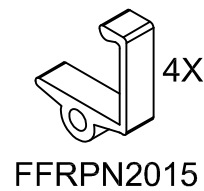
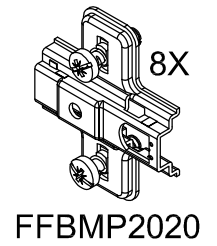
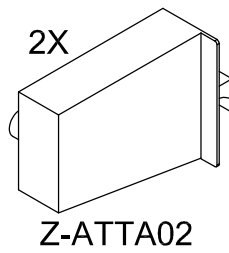
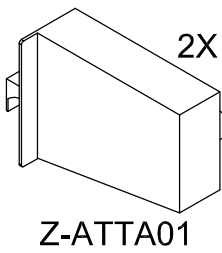
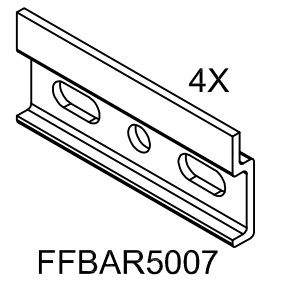
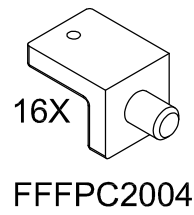
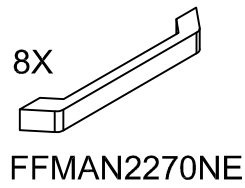
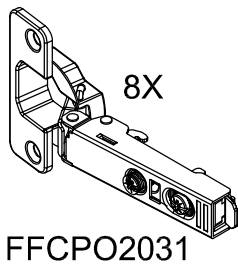
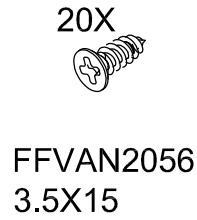
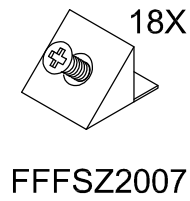
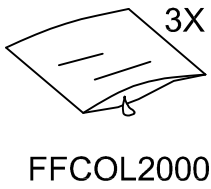
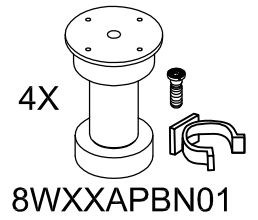
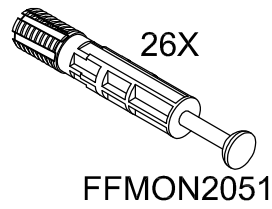
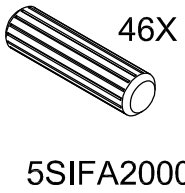

10 INR

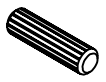

5SIFA2000

4 INR



FFMON2065

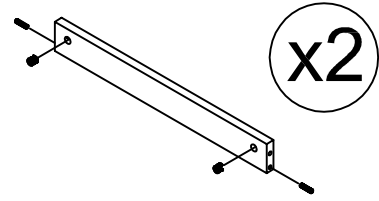
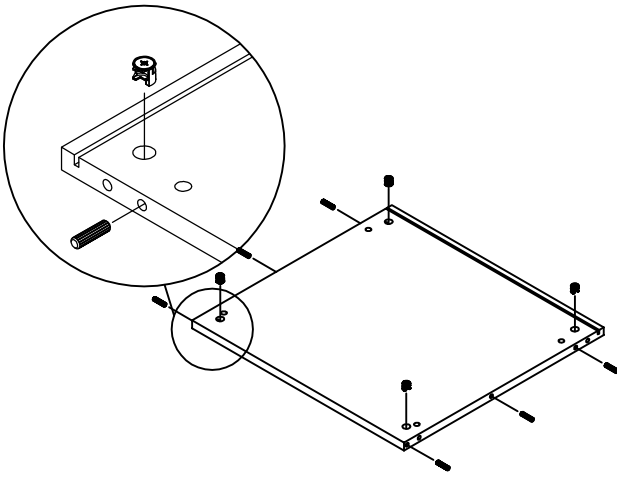

8 INR

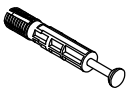

FFMON2051

2 INR

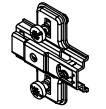

FFBMP2020

2 INR

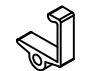

FFRPN2015

2 INR



FFRPN2014

4 INR



FFRPN2016

4 INR

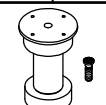

8WXXAPBN01

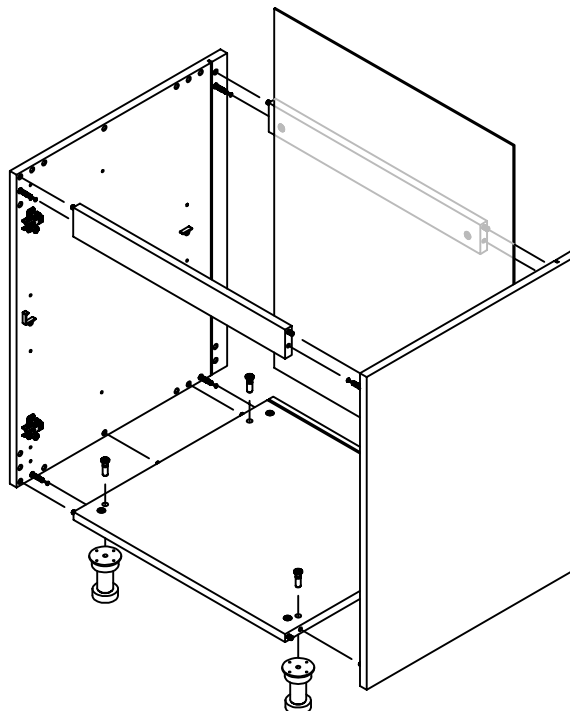
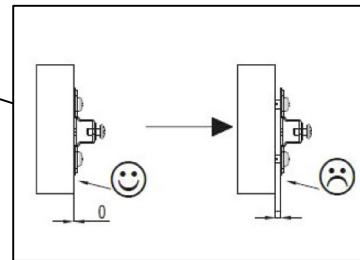
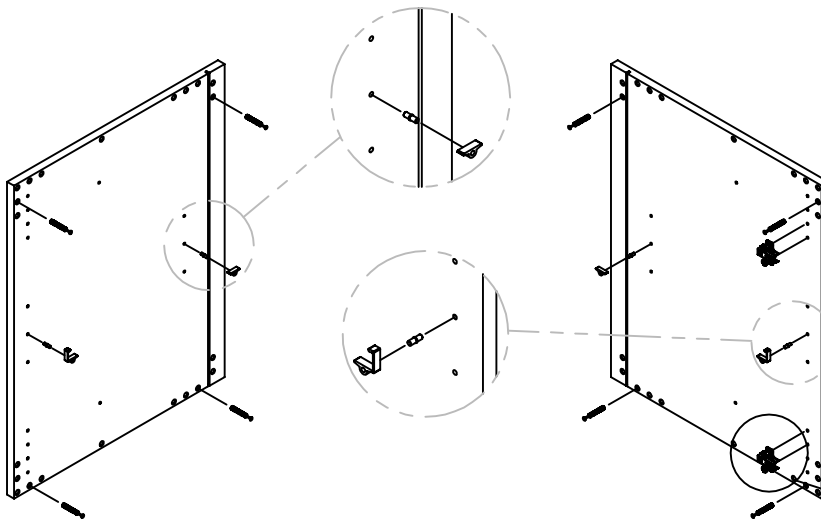

- 4 INR
FFVAN2056
3.5X15
- 2 INR
FFVAN2018
4MAX22
- 2 INR
FFCPO2031
- 1 INR
FFMAN2270NE

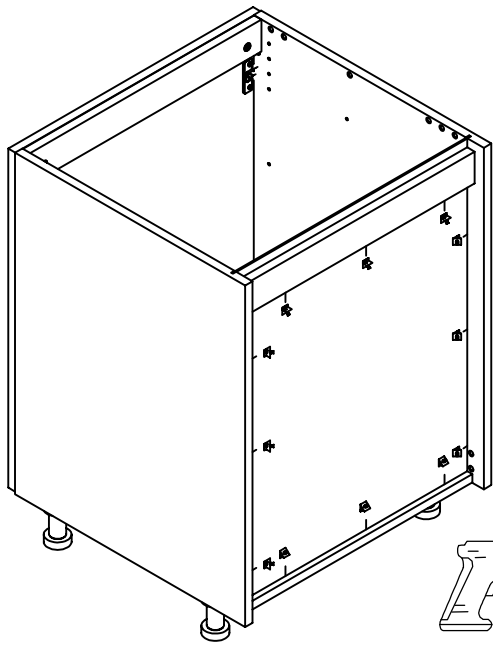

5mm

- 10 INR
FFFSZ2007

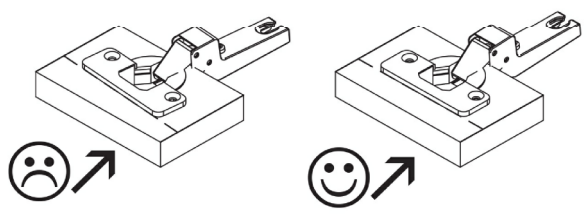

- 2 INR
FFPAR1050

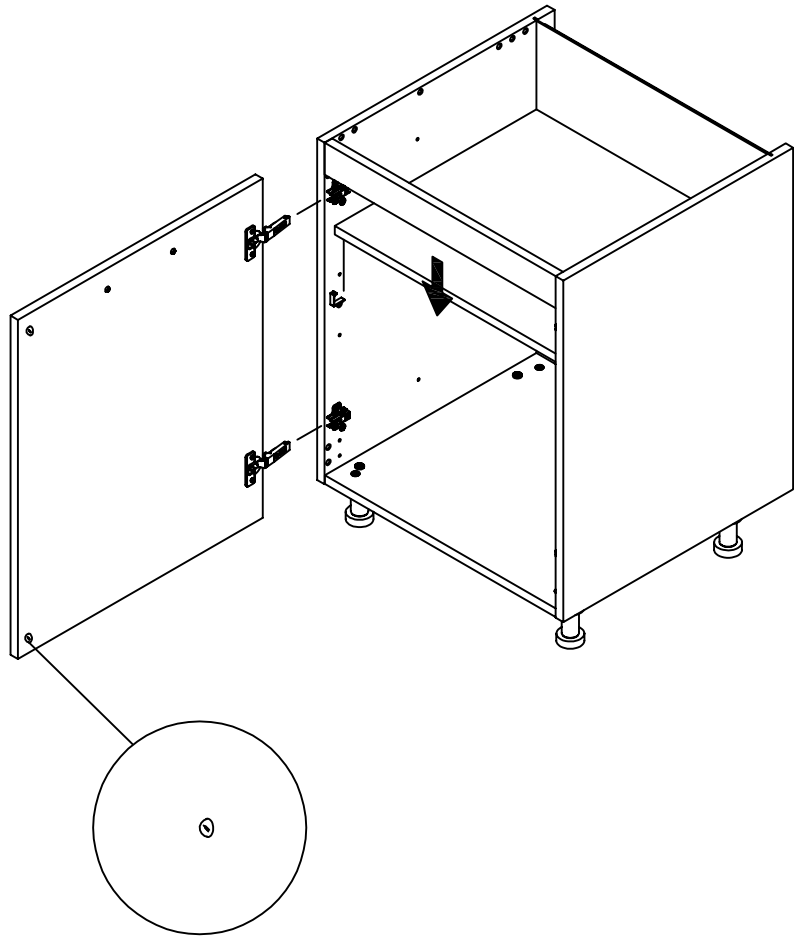
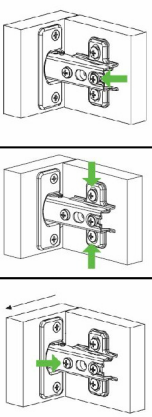

12 INR

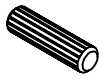

5SIFA2000

10 INR



FFMON2065

6/22

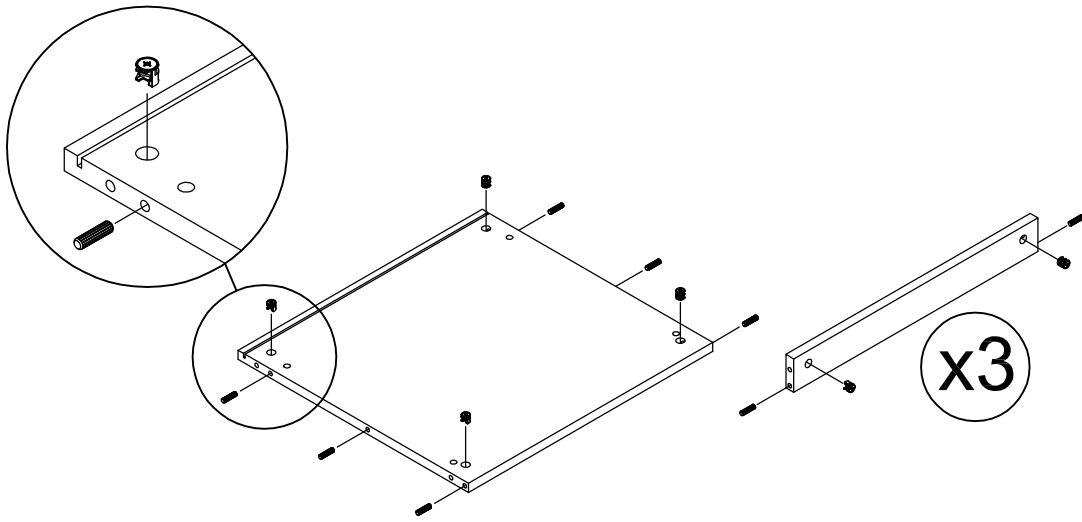

7/22

10 INR

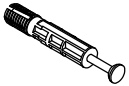

FFMON2051

2 INR

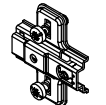

FFBMP2020

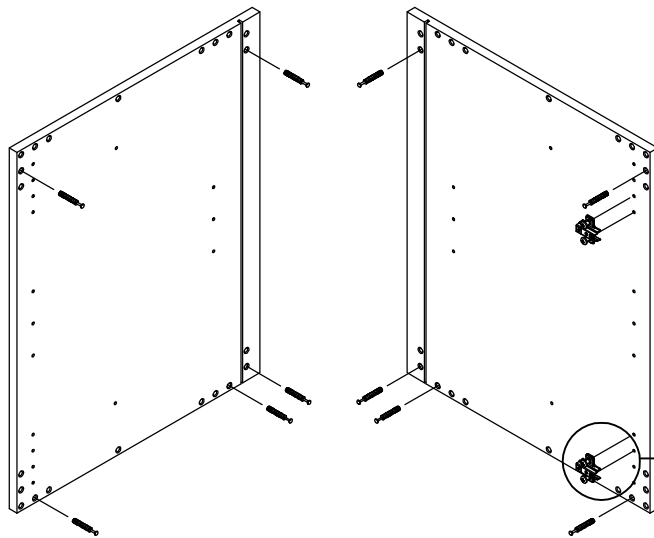

8/22

4 INR



8WXXAPBN01

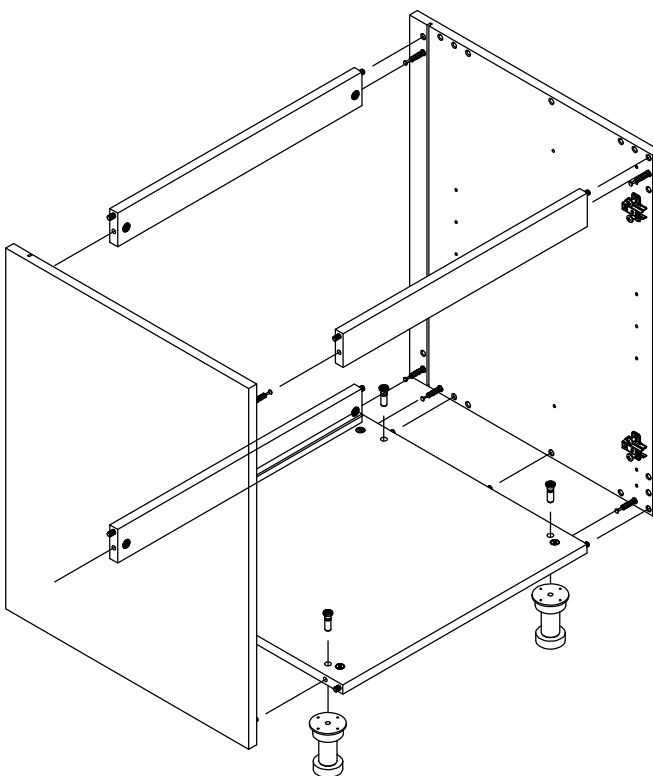

- 4 INR
FFVAN2056
3.5X15
- 2 INR
FFVAN2018
4MAX22
- 2 INR
FFCPO2031
- 1 INR
FFMAN2270NE

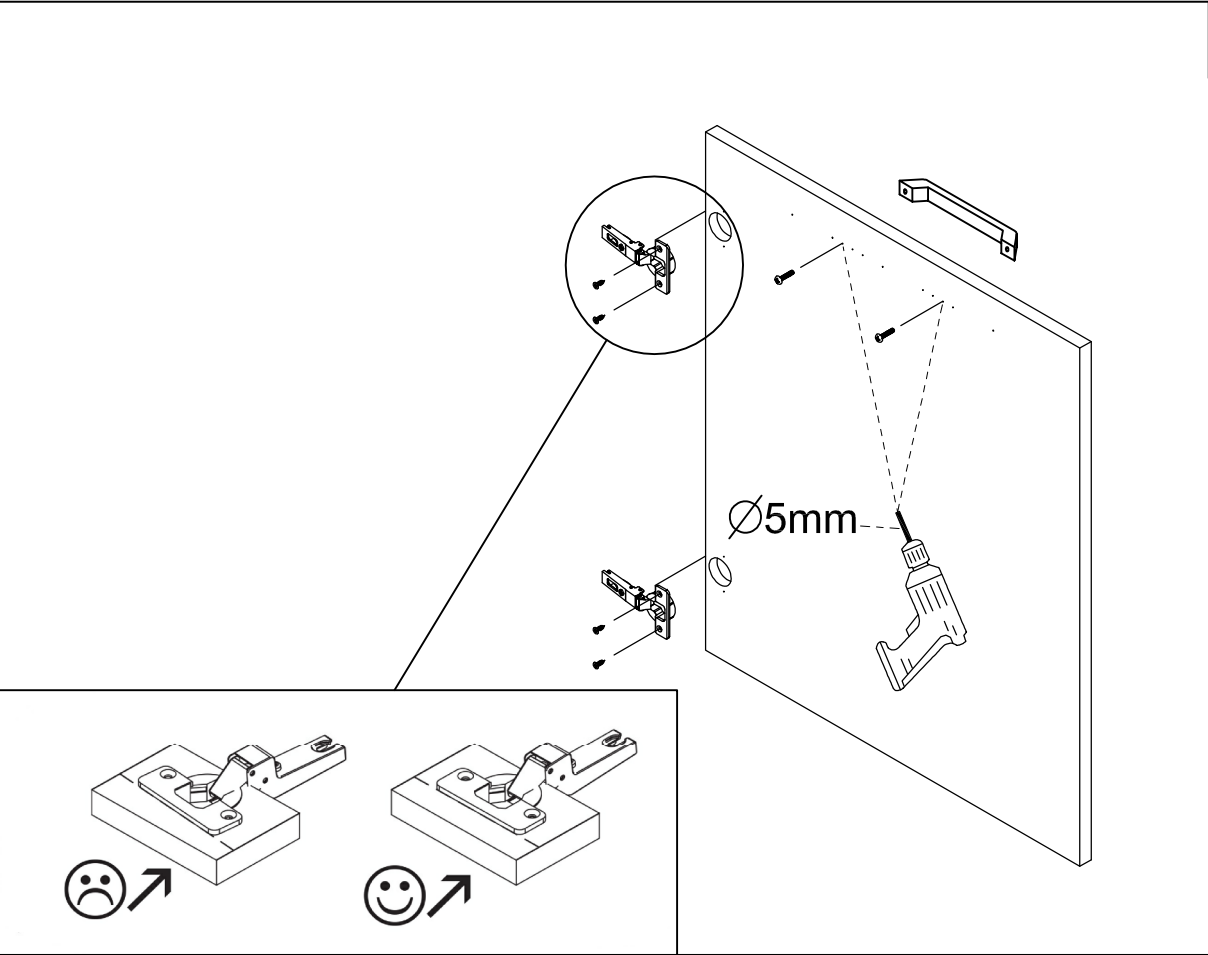

- 2 INR
FFPAR1050
 - 1 INR
9WXXAPLA601
-

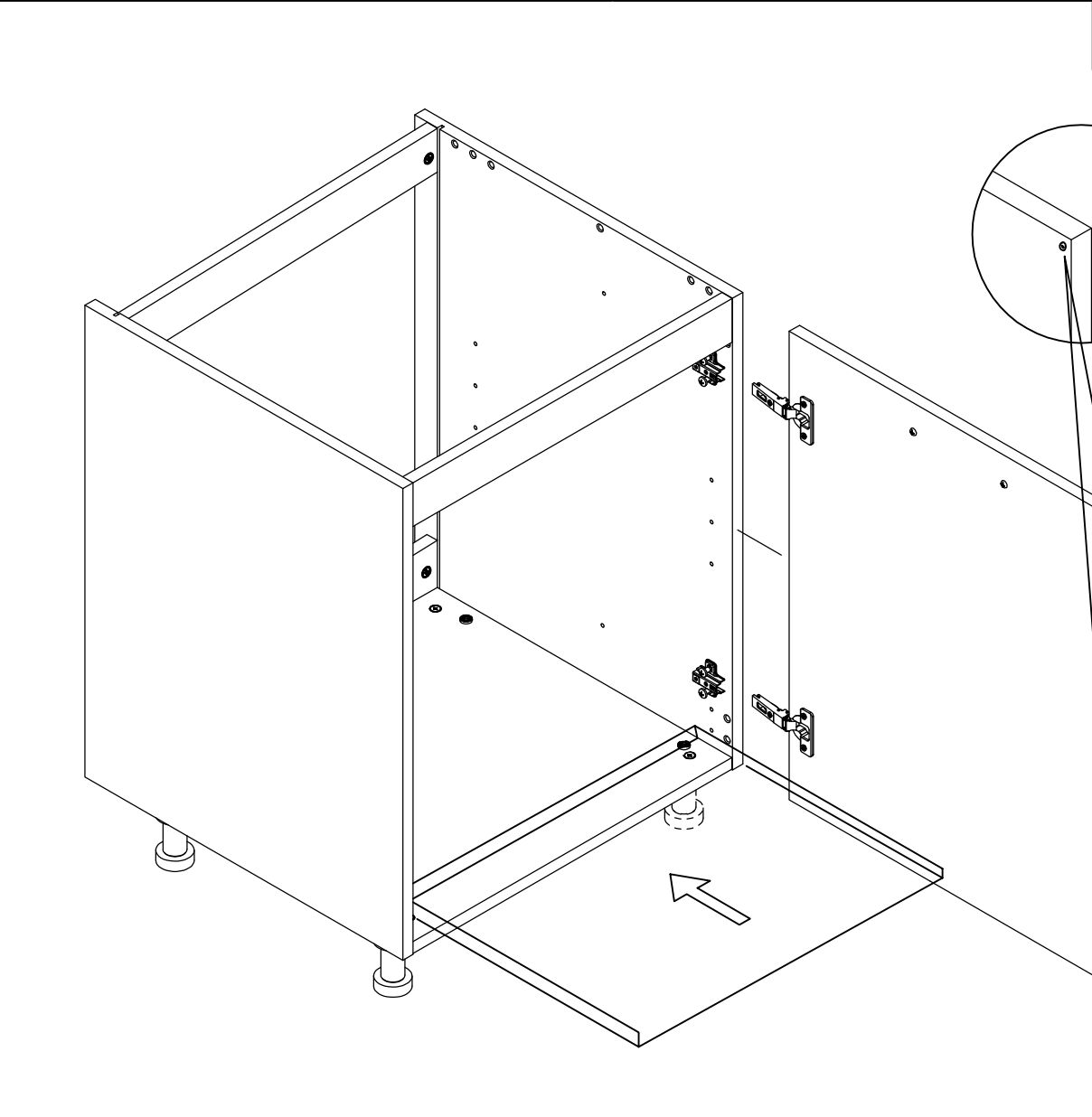

8 INR



5SIFA2000

8 INR



FFMON2065

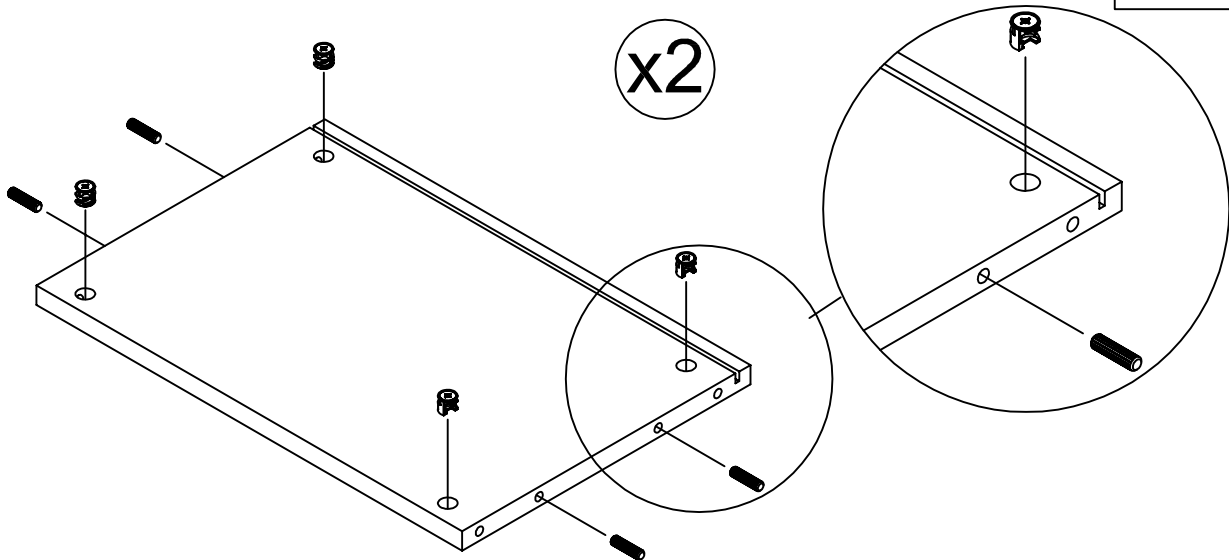

1 INR

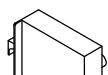

Z-ATTA01

1 INR

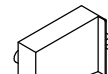

Z-ATTA02

8 INR



FFMON2051

2 INR

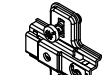

FFBMP2020

2 INR

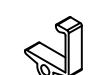

FFRPN2015

2 INR



FFRPN2014

4 INR



FFRPN2016

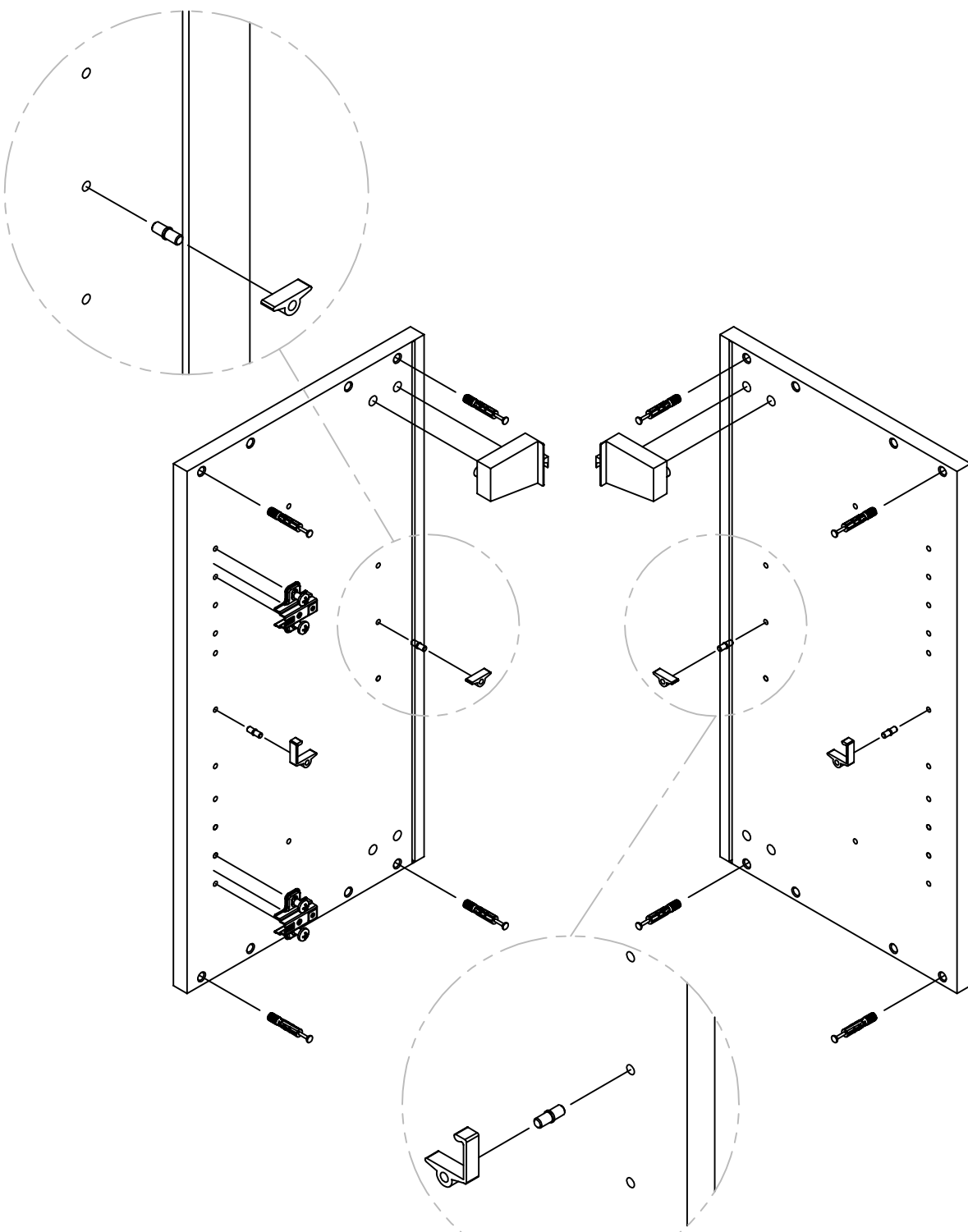

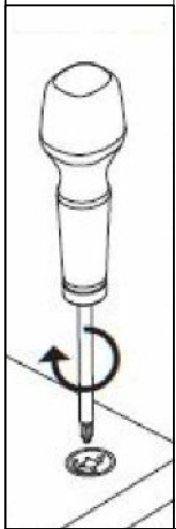
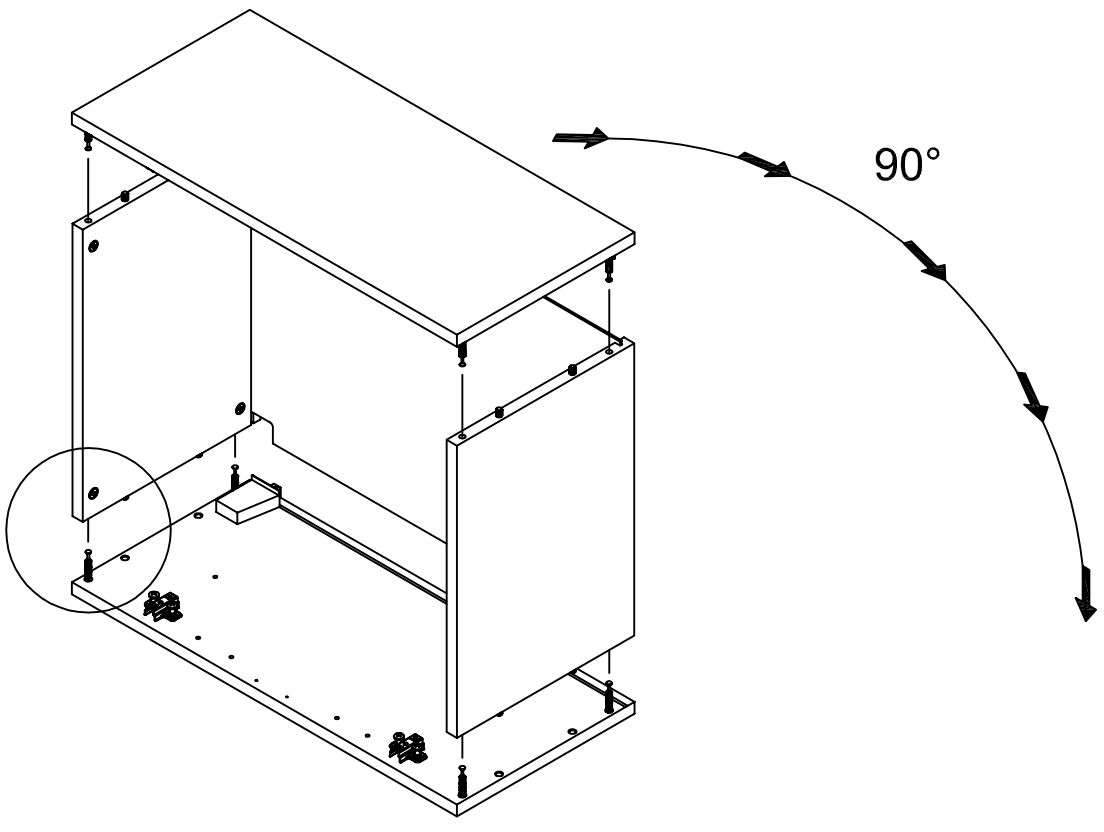

8 NR



FFFSZ2007

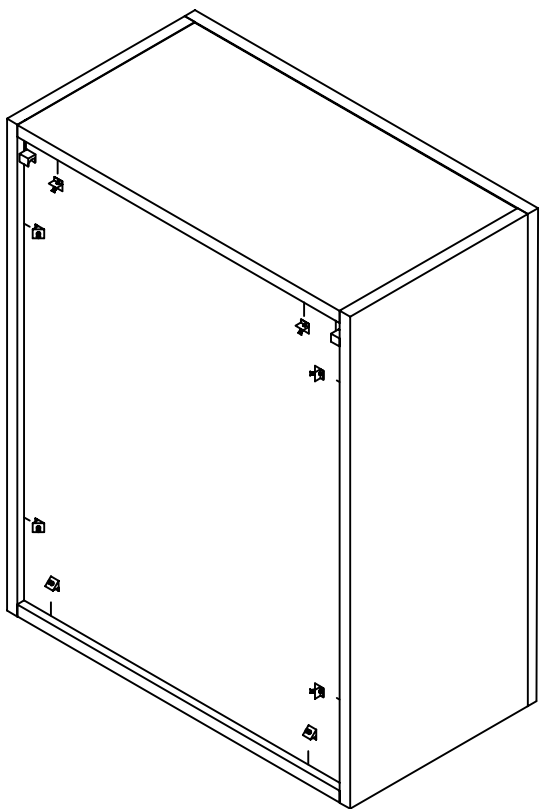

- 6 INR
FFVAN2056
- 2 INR
FFVAN2018
- 3 INR
FFCPO2031
- 1 INR
FFMAN2270NE

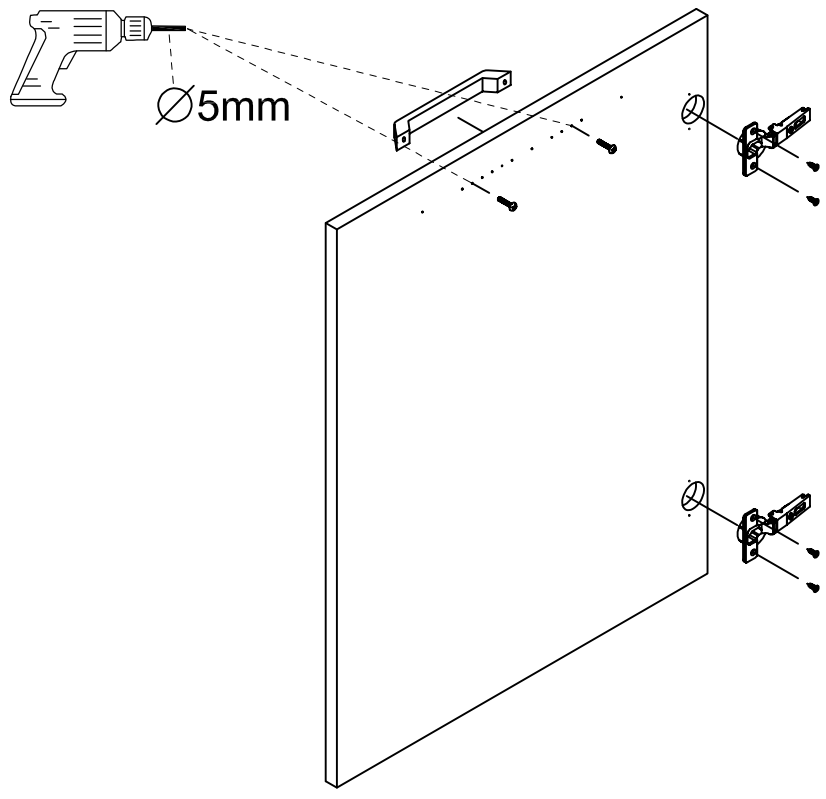

- 2 INR
FFPAR1050

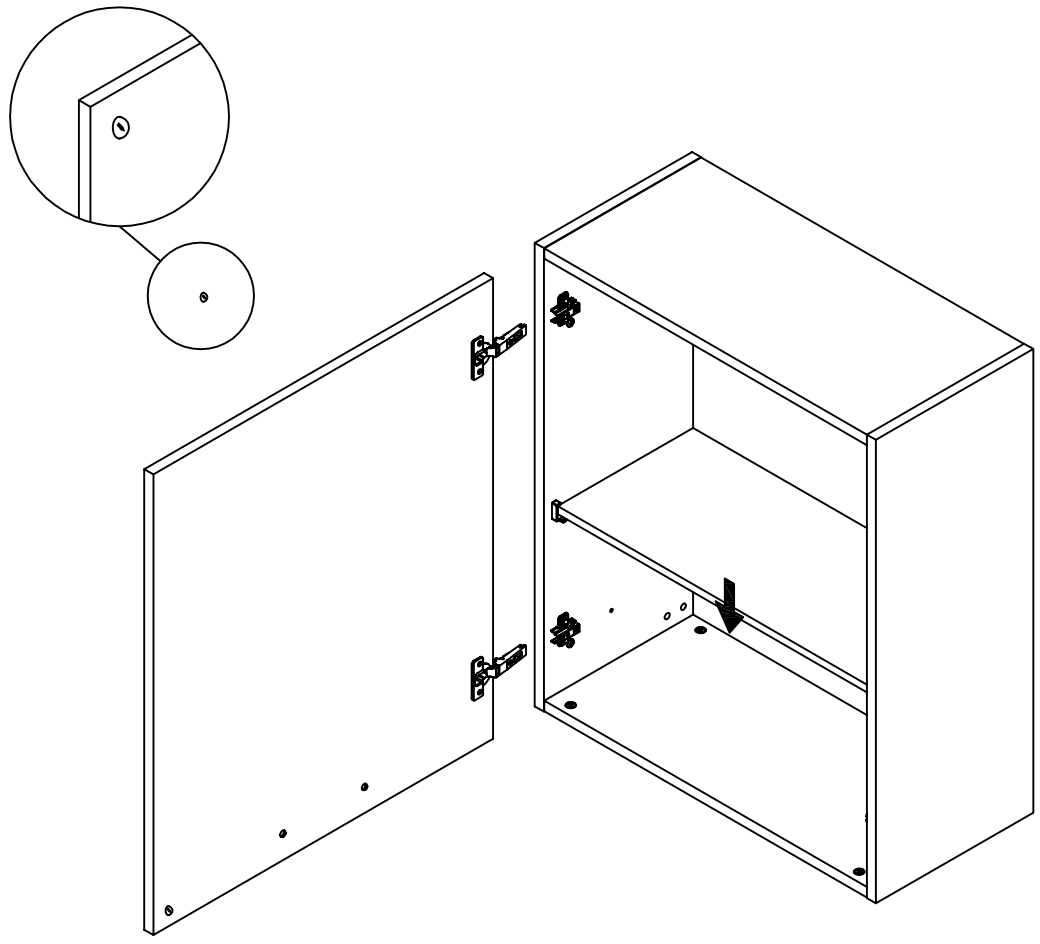

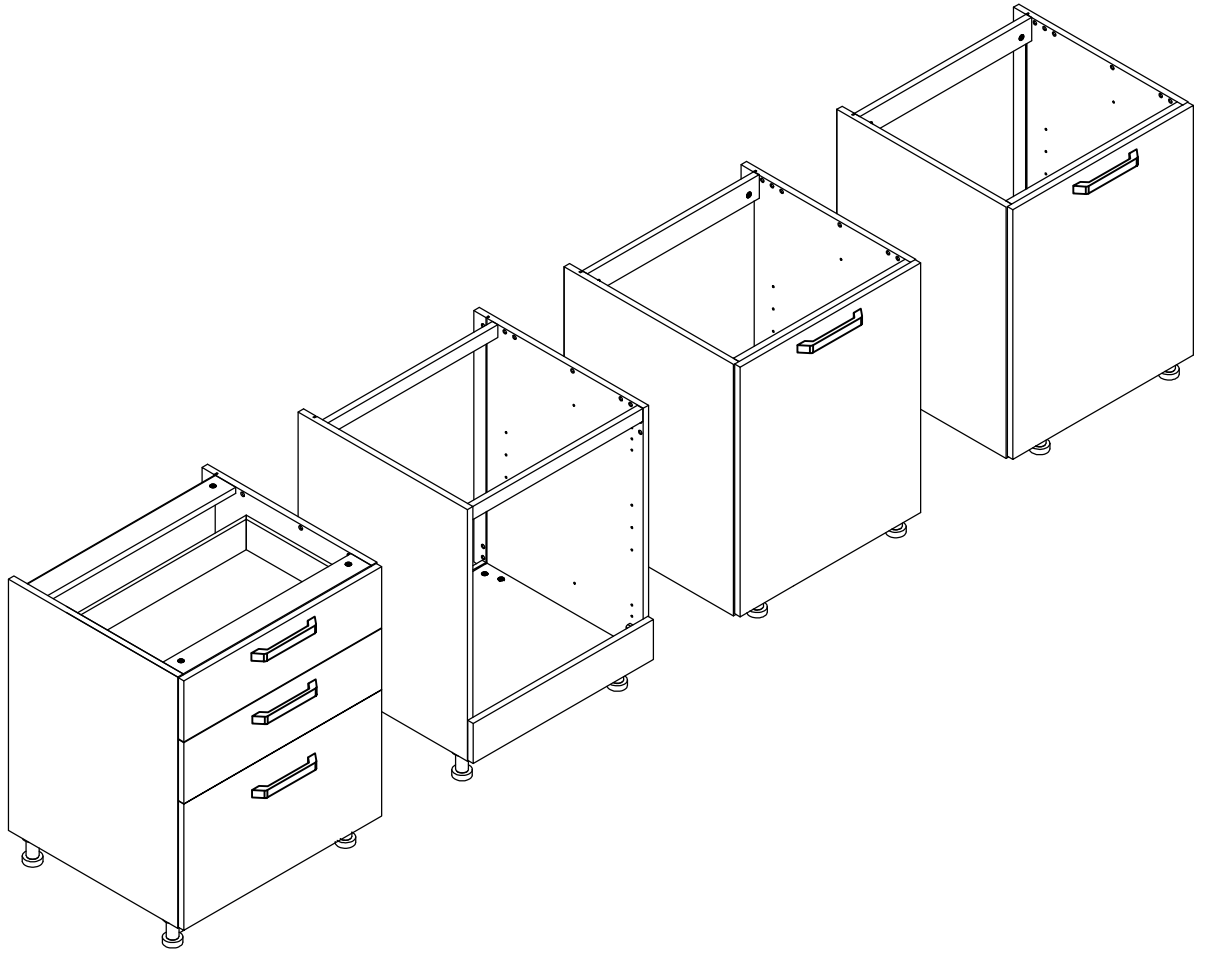

X 4 INR

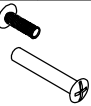

FFGPN2226

X 16 INR



FFFPC2004

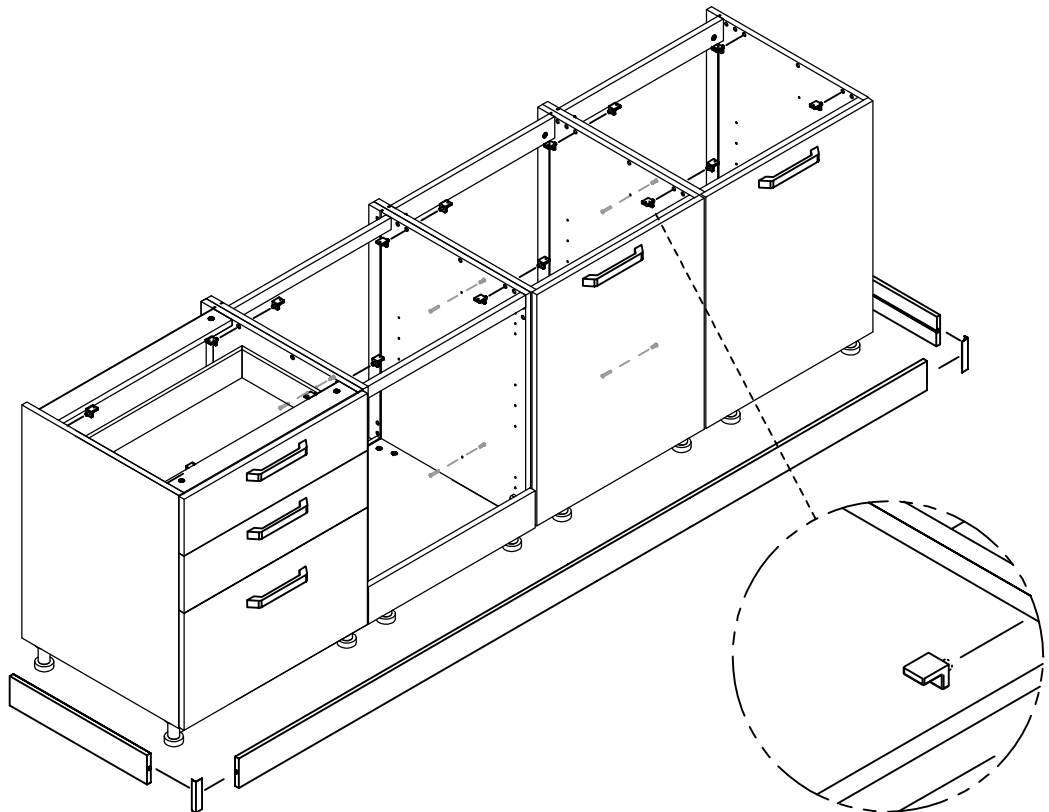
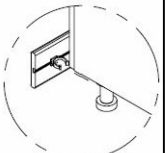
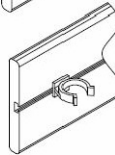
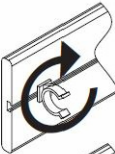

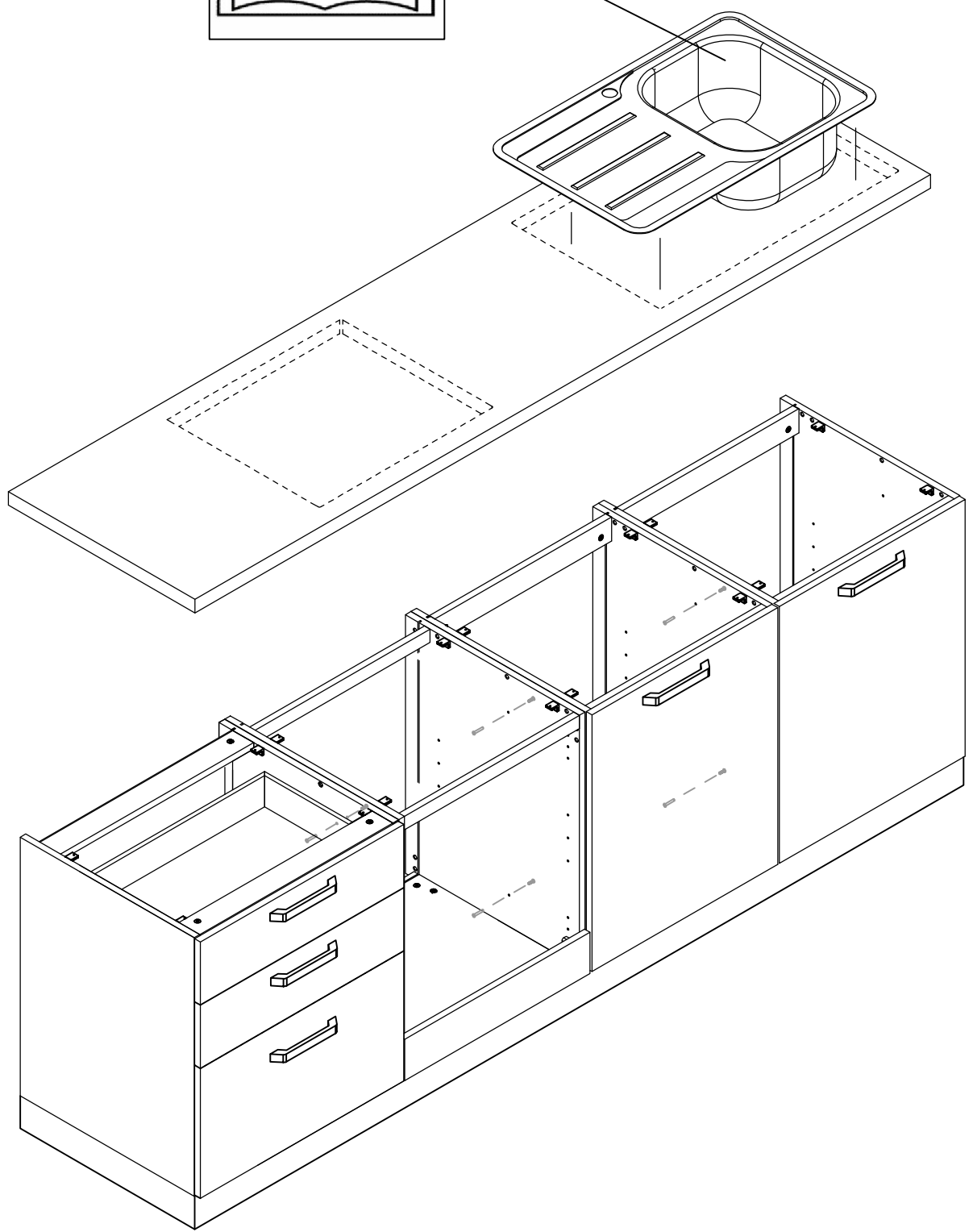
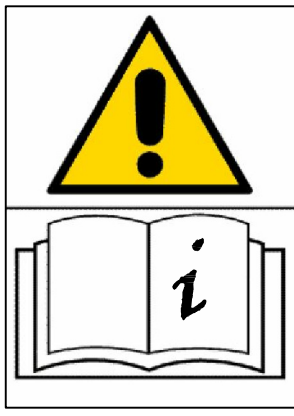
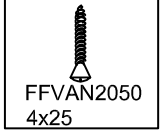

- X 2 INR
FFGPN2226
- X 6 INR
FFBAR5007
- X 3 INR
Z-ATTA02
- X 3 INR
Z-ATTA01
- X 3 INR
FFMAN2270NE
- X 6 INR
FFVAN2018
4MAX22

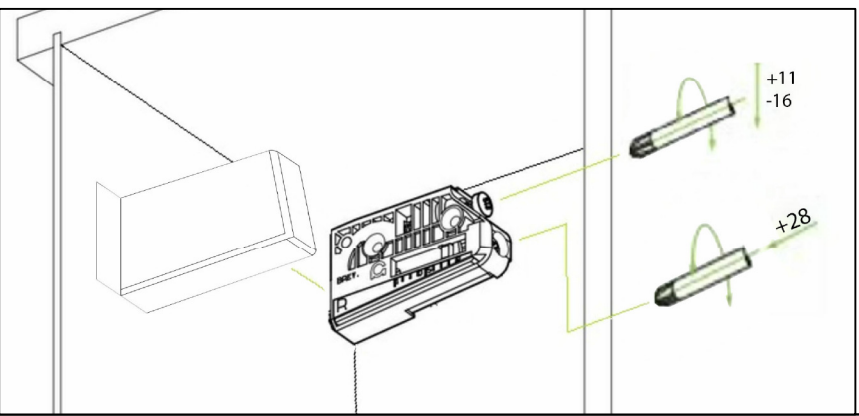
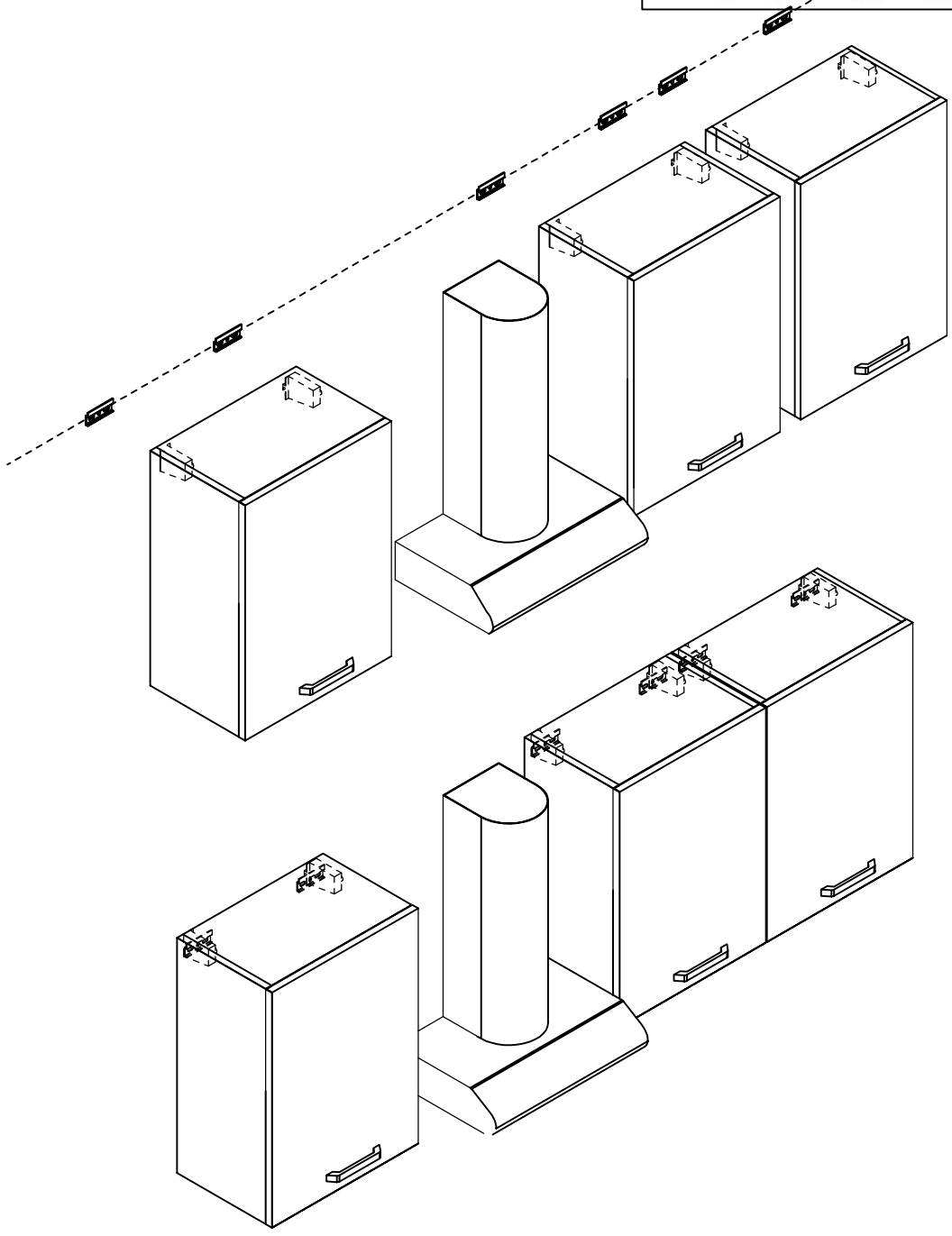
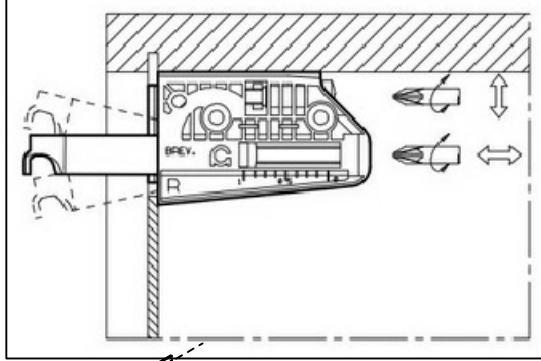

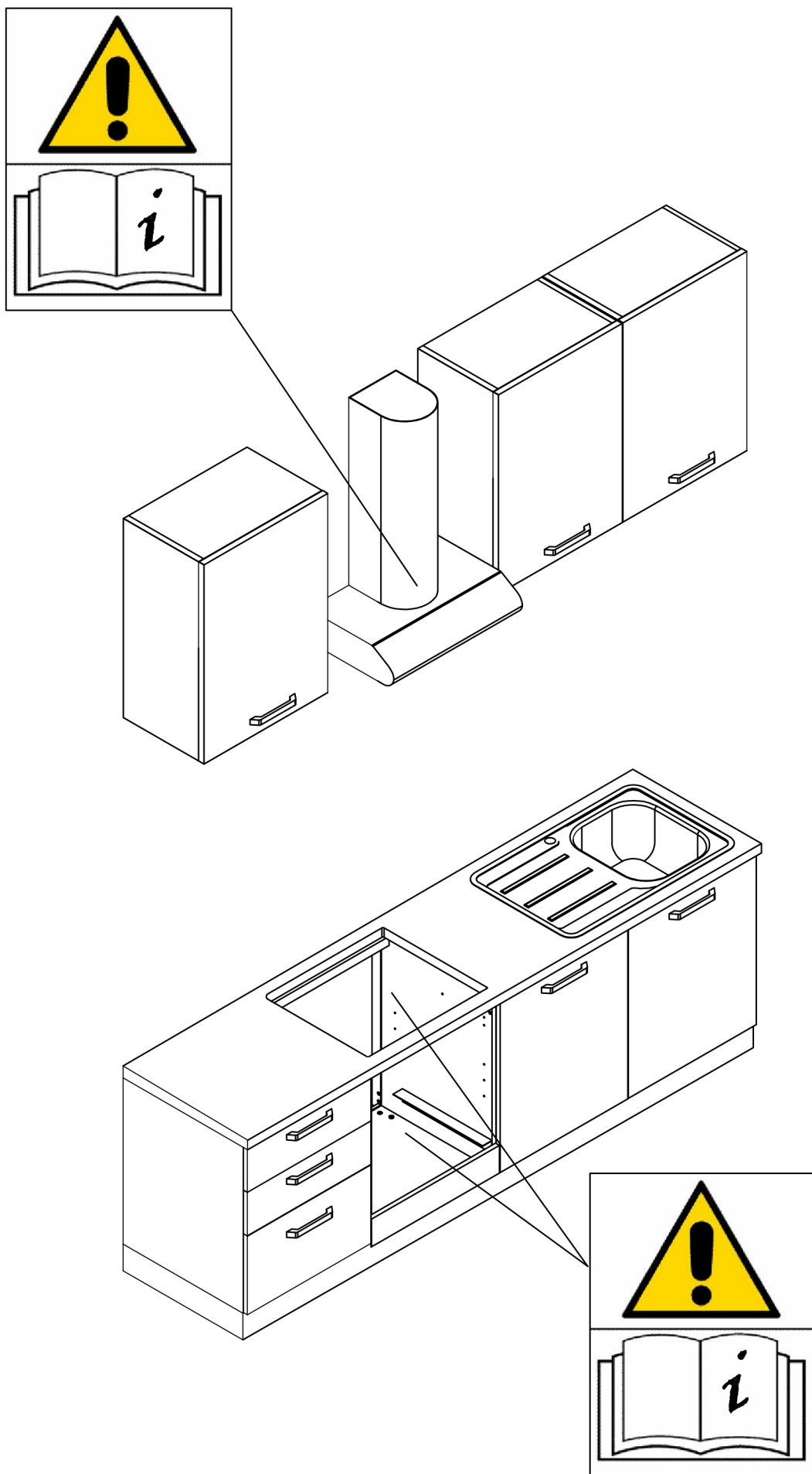

Candy Portogallo :

https://www.candy-home.com/pt_PT/assistencia-tecnica/

Candy Spagna:

[\(https://www.candy-home.com/es_ES/assistencia-tecnica/\)](https://www.candy-home.com/es_ES/assistencia-tecnica/)

