

ELG0006(MY)

APARADOR OSMA 3P 3C

ASSEMBLY INSTRUCTIONS

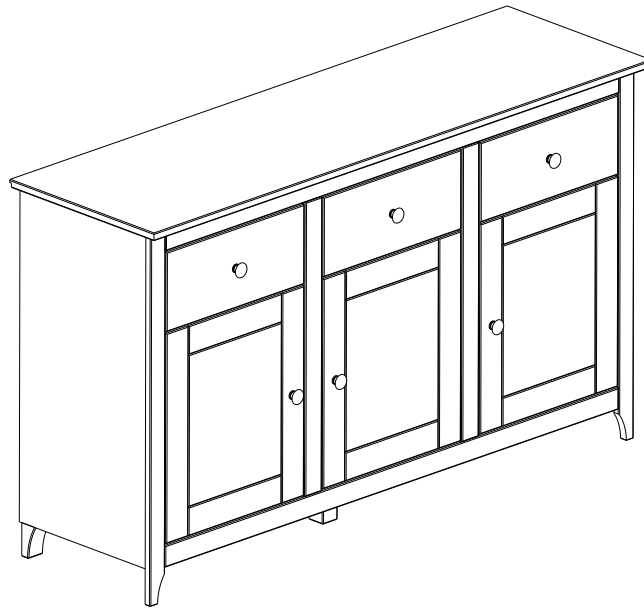

IMPORTANT
FOR DOMESTIC USE ONLY
 PLEASE READ BEFORE YOU CONTINUE FURTHER

CARE AND MAINTENANCE

After unpacking this product please keep the original packaging in case it needs to be returned for any reason.

- Please ensure all fittings and parts are present before commencing with assembly.
- Never drag or push products as this could cause damage to the joints making it inferior.
- We strongly recommend that you keep children away from your work area.
- We recommend that you lay a blanket or sheet on the floor to avoid damage to both your floor and the product.
- Assemble this product as close to its final position as possible.
- Do not place this product next to a radiator or in direct sunlight.
- Do not drag or push items across your high gloss furniture as this may cause the surface to scratch
- Wood is a natural product and may expand if subjected to damp and may shrink or crack if subjected to heat. Therefore it is recommended that room temperature is maintained, with no sudden temperature fluctuations.

- Make sure any spillage is wiped off immediately.
- Do not place hot or chilled items directly on to the surface, use a place mat or marking will occur.
- For general cleaning use a soft cotton or micro fibre cloth, and do not use detergents of any kind.
- From time to time it may be necessary to tighten fittings, regular inspections should be carried out.
- Do not place on a wet or damp floor as staining may occur to your floor.

CUIDADOS Y MANUTENCION

Por favor, lea atentamente:

1 - NO mantener este producto cerca de radiadores, chimeneas o expuesto al sol. Es recomendable mantener una temperatura ambiente estable.

2 - La madera es un producto natural. Pueden haber algunas variaciones de tonalidad.

3 - No colocar productos húmedos directamente sobre el mueble. Tampoco muy frios, ni muy calientes, ya que pueden dejar marcas.

4 - Para la limpieza general, utilizar un trapo limpio y seco. No utilizar detergentes ni productos de limpieza.

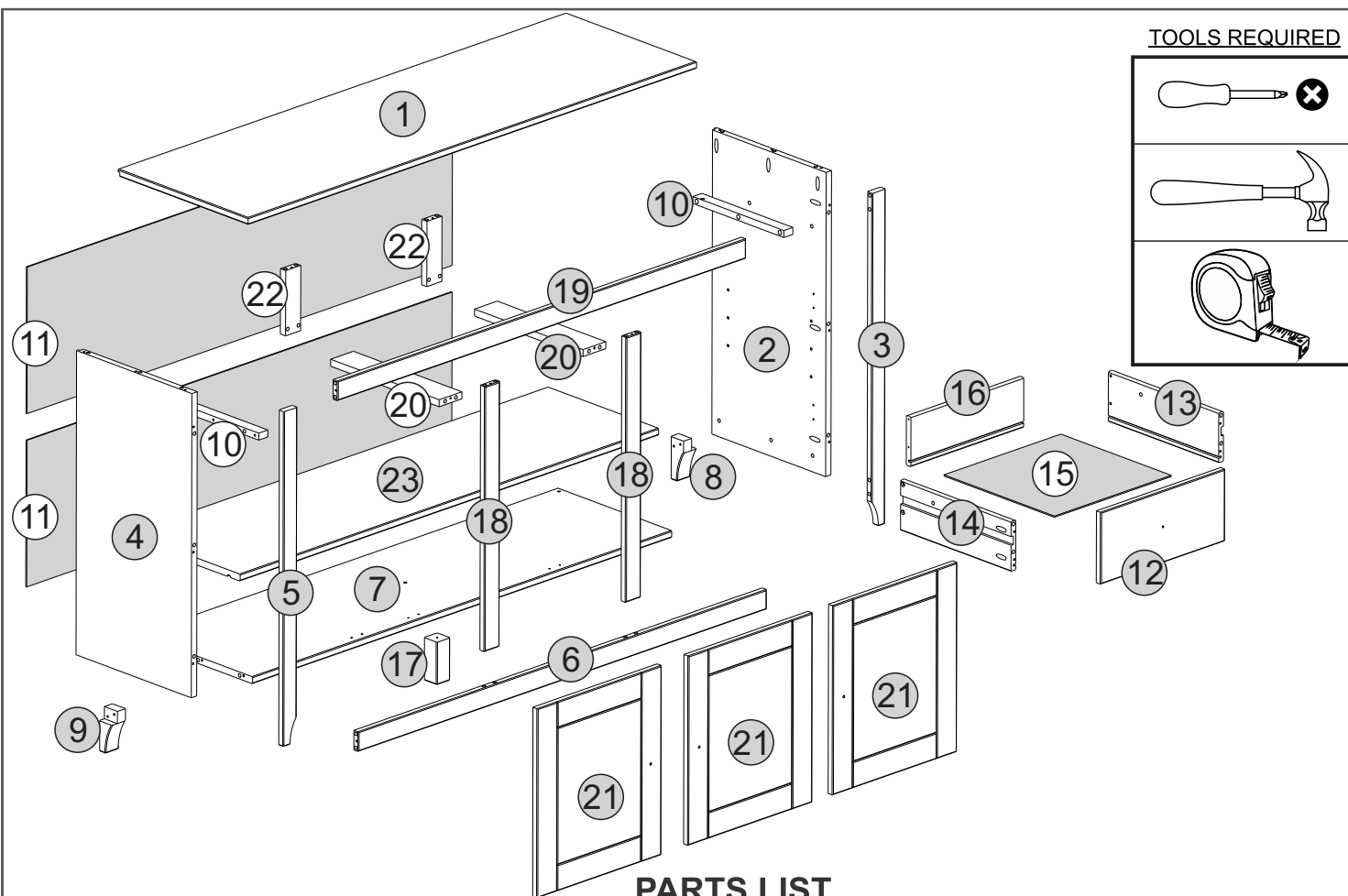









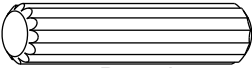

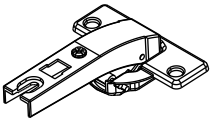

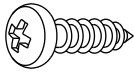

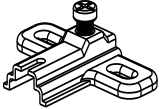
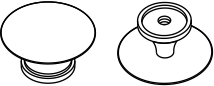
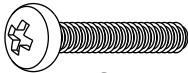
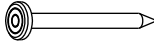
PARTS LIST

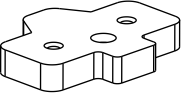
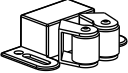
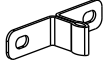
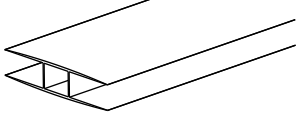
Please Note:
The highlighted parts below have been stamped with the part number to help identify them during assembly

<u>Part Number</u>	<u>Part Description</u>	<u>Quantity</u>	<u>Carton</u>
1	Top Panel	1	1/1
2	Right Side Panel	1	1/1
3	Right Front Upright	1	1/1
4	Left Side Panel	1	1/1
5	Left Front Upright	1	1/1
6	Lower Front Crossbeam	2	1/1
7	Base	1	1/1
8	Right Back Foot	1	1/1
9	Left Back Foot	1	1/1
10	Drawer Runner	2	1/1
11	Back Panel	2	1/1
12	Drawer Front	3	1/1
13	Right Drawer Side	3	1/1
14	Left Drawer Side	3	1/1
15	Drawer Bottom	3	1/1
16	Drawer Back Panel	3	1/1
17	Center Foot	1	1/1
18	Center Front Upright	2	1/1
19	Upper Front Crossbeam	1	1/1
20	Center Runner	2	1/1
21	Door	3	1/1
22	Center Runner Support	2	1/1
23	Adjustable Shelf	1	1/1

FITTINGS LIST

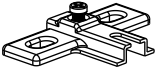
<p>A</p>  <p>Dowel Ø8,0 x 30mm (68x) +1/2</p>	<p>B</p>  <p>Screw Ø3,5 x 30mm (63x) +1/2</p>	<p>C</p>  <p>Flan Head Screw Ø4,0 x 35mm (6x)</p>	<p>D</p>  <p>Hinge (Right) (2x)</p>
<p>E</p>  <p>Screw Ø4,0 x 25mm (8x)</p>	<p>F</p>  <p>Screw Ø3,5 x 14mm (36x) +1/2</p>	<p>G</p>  <p>Hinge (Right) (4x)</p>	<p>H</p>  <p>Hinge (Left) (4x)</p>
<p>I</p>  <p>Metal Knob (3x)</p>	<p>J</p>  <p>Screw ØM4 x 22mm (3x) +1/2</p>	<p>K</p>  <p>Nail 8 x 8 (30x) +1/2</p>	<p>L</p>  <p>Corner (4x)</p>
<p>M</p>  <p>Hinge Spacer (4x)</p>	<p>N</p>  <p>Catcher (3x)</p>	<p>O</p>  <p>Knocker (3x)</p>	<p>P</p>  <p>Back Panel Strip 1250mm (1x)</p>
<p>Q</p>  <p>Strap (1x)</p>	<p>R</p>  <p>Washer (2x)</p>	<p>S</p>  <p>Glue (1x)</p>	<p>T</p>  <p>Support (4x)</p>
<p>U</p>  <p>Screw Ø6,0 x 60mm (1x)</p>	<p>V</p>  <p>Hinge (Left) (2x)</p>		

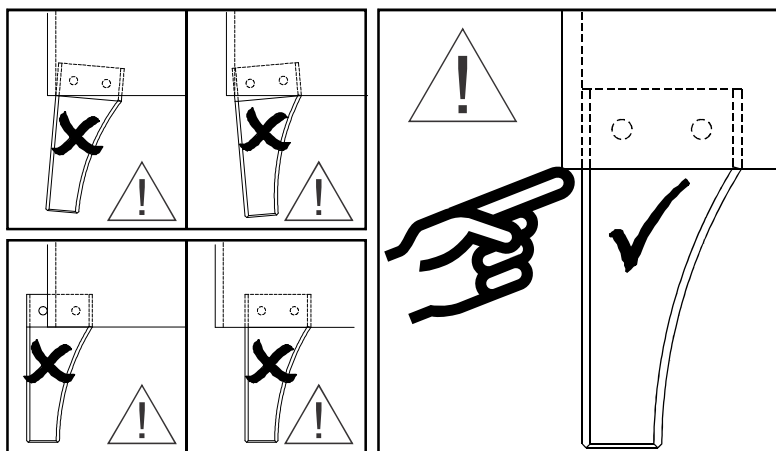



PLEASE USE THE ABOVE EXAMPLE TO ASSEMBLE THE FEET ON STEP 2.

STEP 1

PARTS REQUIRED

- 2 - RIGHT SIDE PANEL x1
- 4 - LEFT SIDE PANEL x1

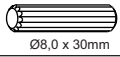
HARDWARE REQUIRED

- A  12
Ø8,0 x 30mm
- S  01
Glue
- T  04
Support

TOOLS REQUIRED

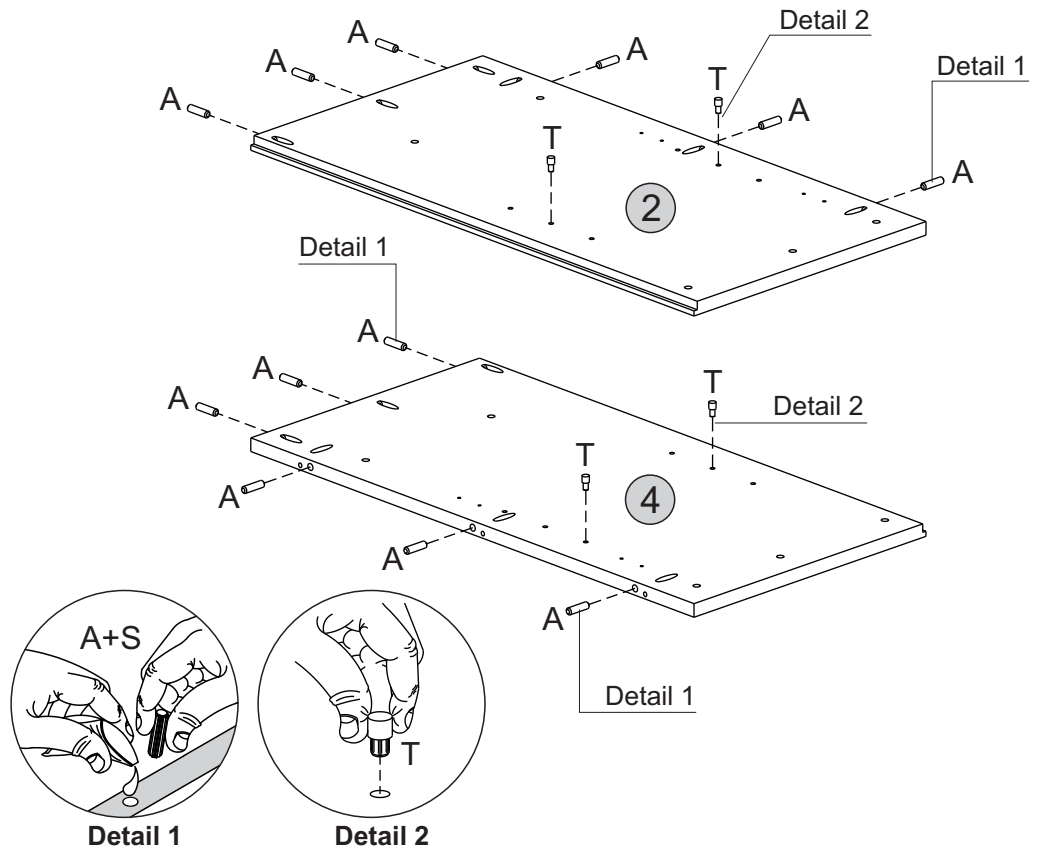
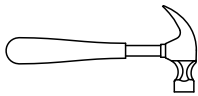

STEP 2

PARTS REQUIRED

- 2 - RIGHT SIDE PANEL x1
- 4 - LEFT SIDE PANEL x1
- 8 - RIGHT BACK FOOT x1
- 9 - LEFT BACK FOOT x1

HARDWARE REQUIRED

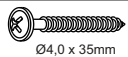
- C  04
Ø4,0 x 35mm

TOOLS REQUIRED

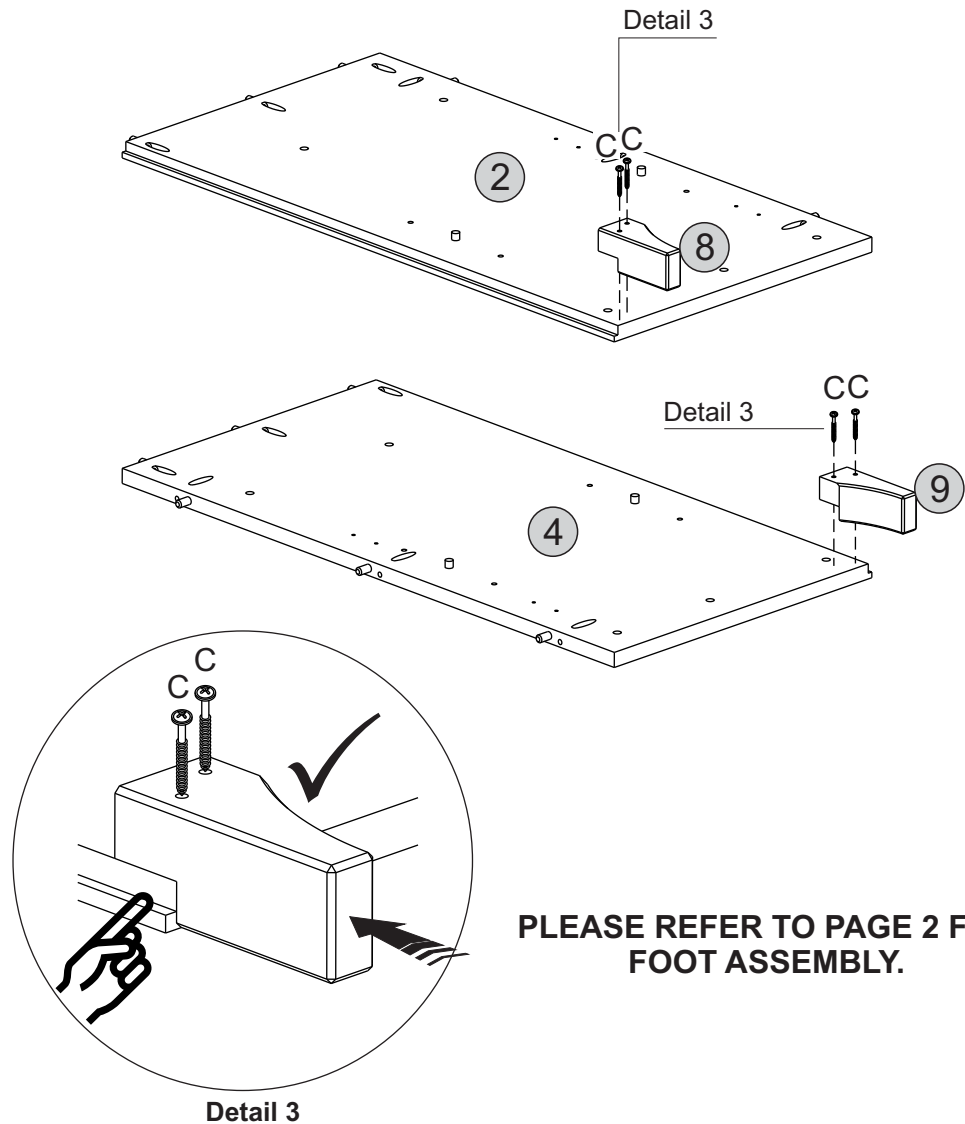
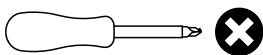

PLEASE REFER TO PAGE 2 FOR FOOT ASSEMBLY.

STEP 3

PARTS REQUIRED

3 - RIGHT FRONT UPRIGHT x1

5 - LEFT FRONT UPRIGHT x1

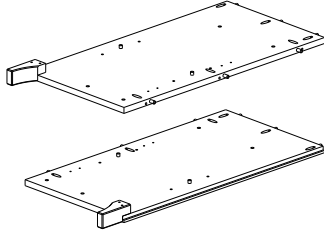

HARDWARE REQUIRED

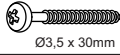
B  06
Ø3,5 x 30mm

S  01
Glue

TOOLS REQUIRED

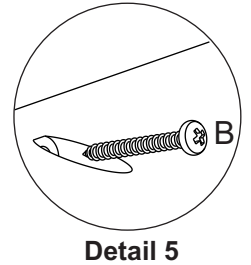
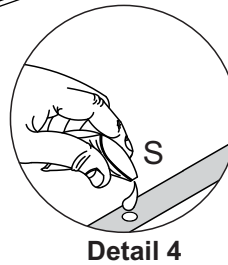
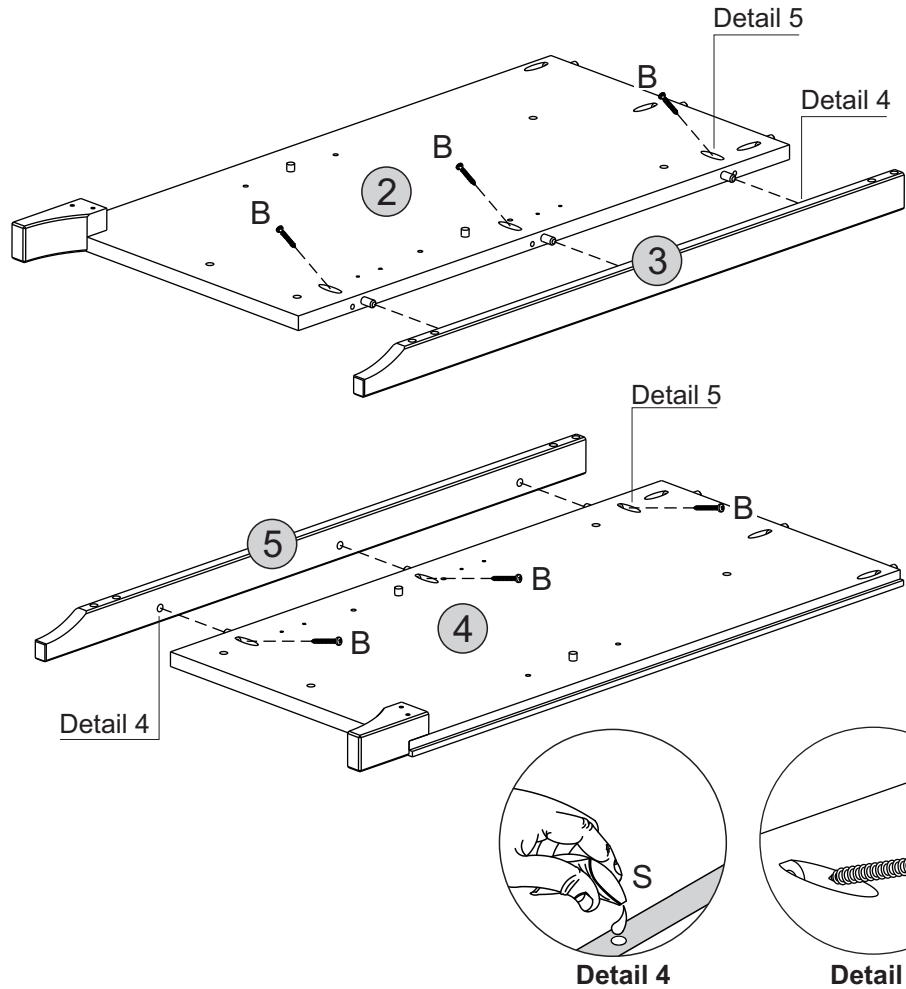
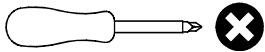

STEP 4

PARTS REQUIRED

2 - RIGHT SIDE PANEL x1

4 - LEFT SIDE PANEL x1

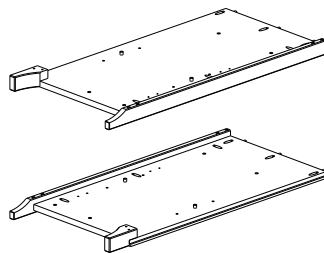

HARDWARE REQUIRED

E  08
Ø4,0 x 25mm

H  04
Hinge (Left)

M  04
Hinge Spacer

TOOLS REQUIRED

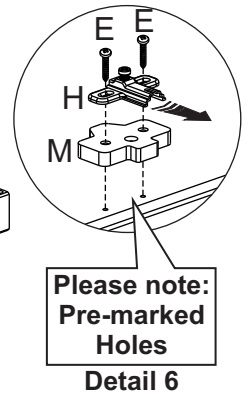
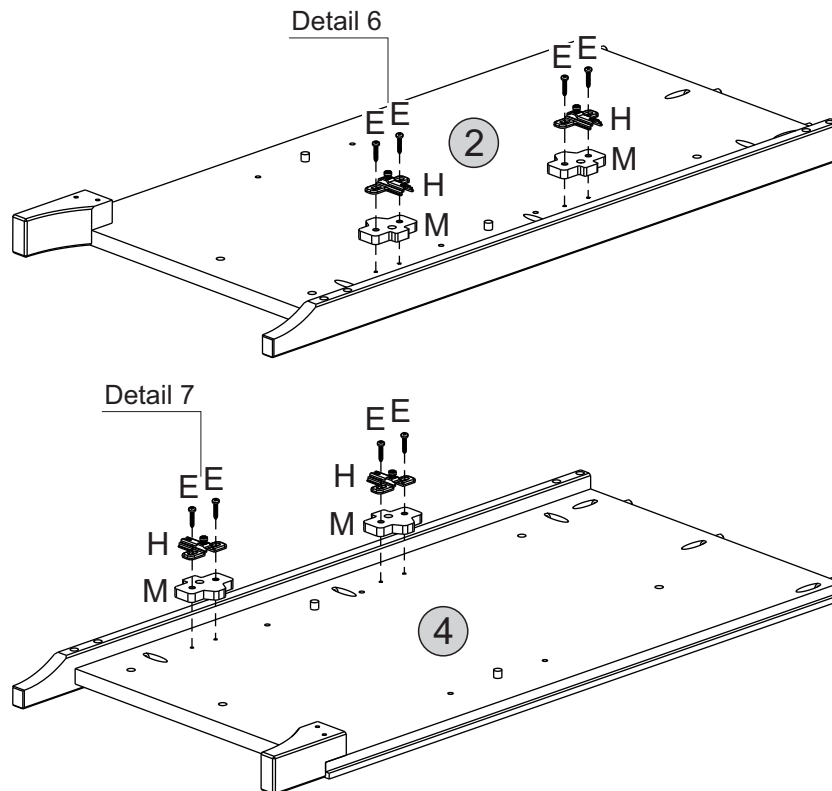
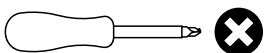

Please note:
Pre-marked
Holes
Detail 6

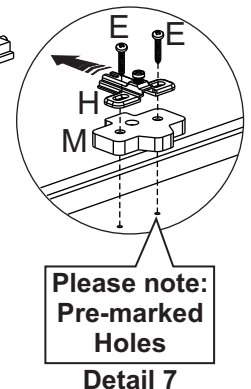

Please note:
Pre-marked
Holes
Detail 7

STEP 5

PARTS REQUIRED

6 - LOWER FRONT CROSSBEAM x1

18 - CENTER FRONT UPRIGHT x2

19 - UPPER FRONT CROSSBEAM x1

HARDWARE REQUIRED

A  16
Ø8,0 x 30mm

F  02
Ø3,5 x 14mm

L  02
Corner

S  01
Glue

TOOLS REQUIRED

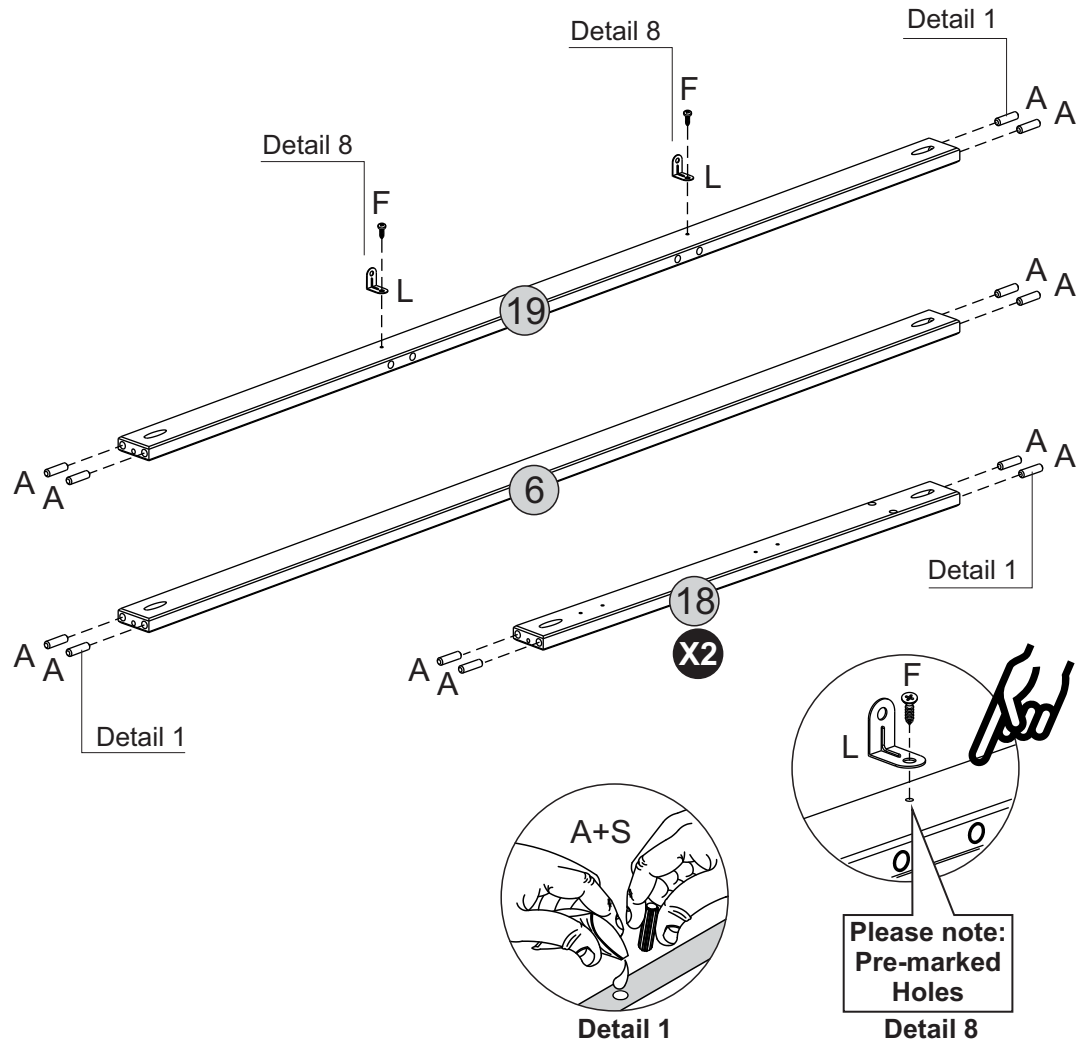
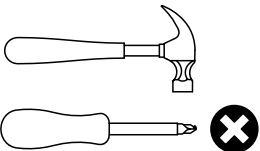

STEP 6

PARTS REQUIRED

6 - LOWER FRONT CROSSBEAM x1

18 - CENTER FRONT UPRIGHT x2

19 - UPPER FRONT CROSSBEAM x1

HARDWARE REQUIRED

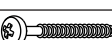
B  04
Ø3,5 x 30mm

S  01
Glue

TOOLS REQUIRED

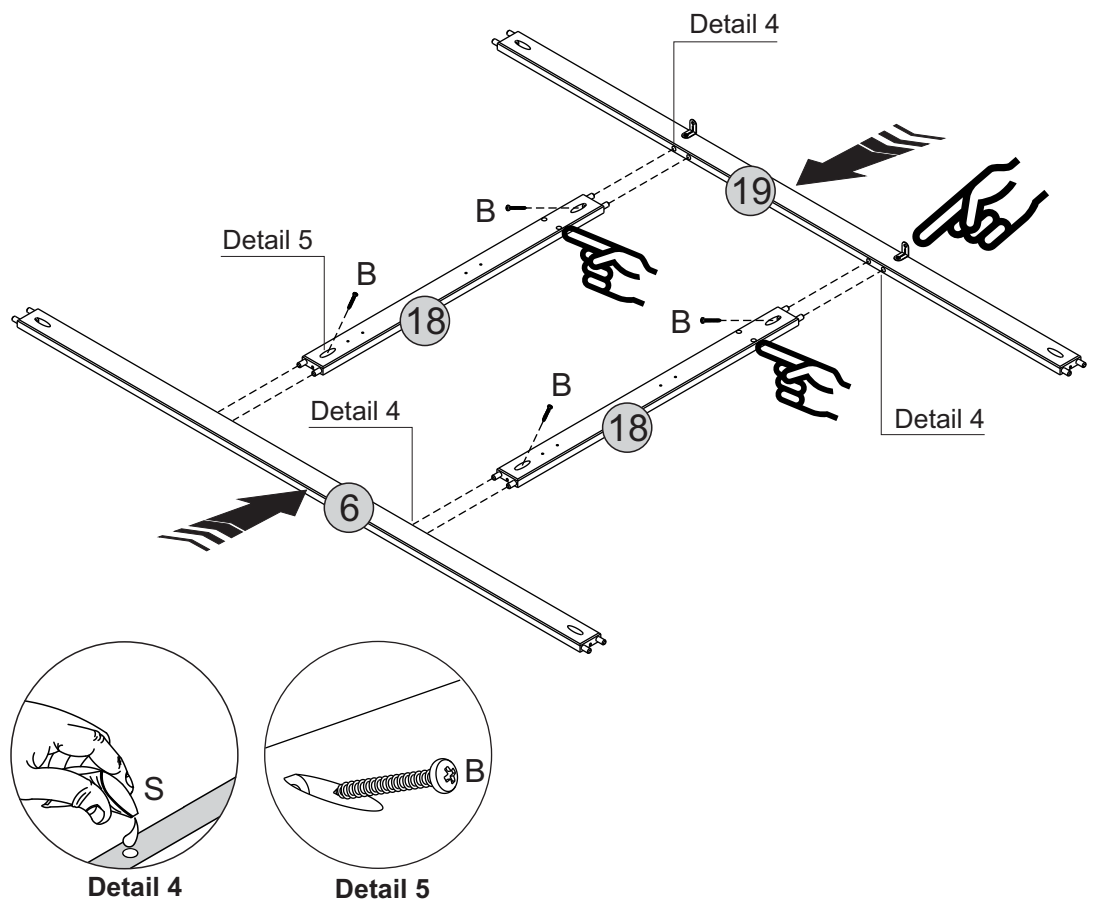
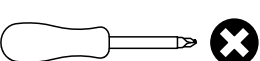



STEP 7

PARTS REQUIRED

7 - BASE	x1
----------	----

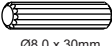
HARDWARE REQUIRED

A		06
Ø8,0 x 30mm		

F		02
Ø3,5 x 14mm		

L		02
Corner		

S		01
Glue		

TOOLS REQUIRED

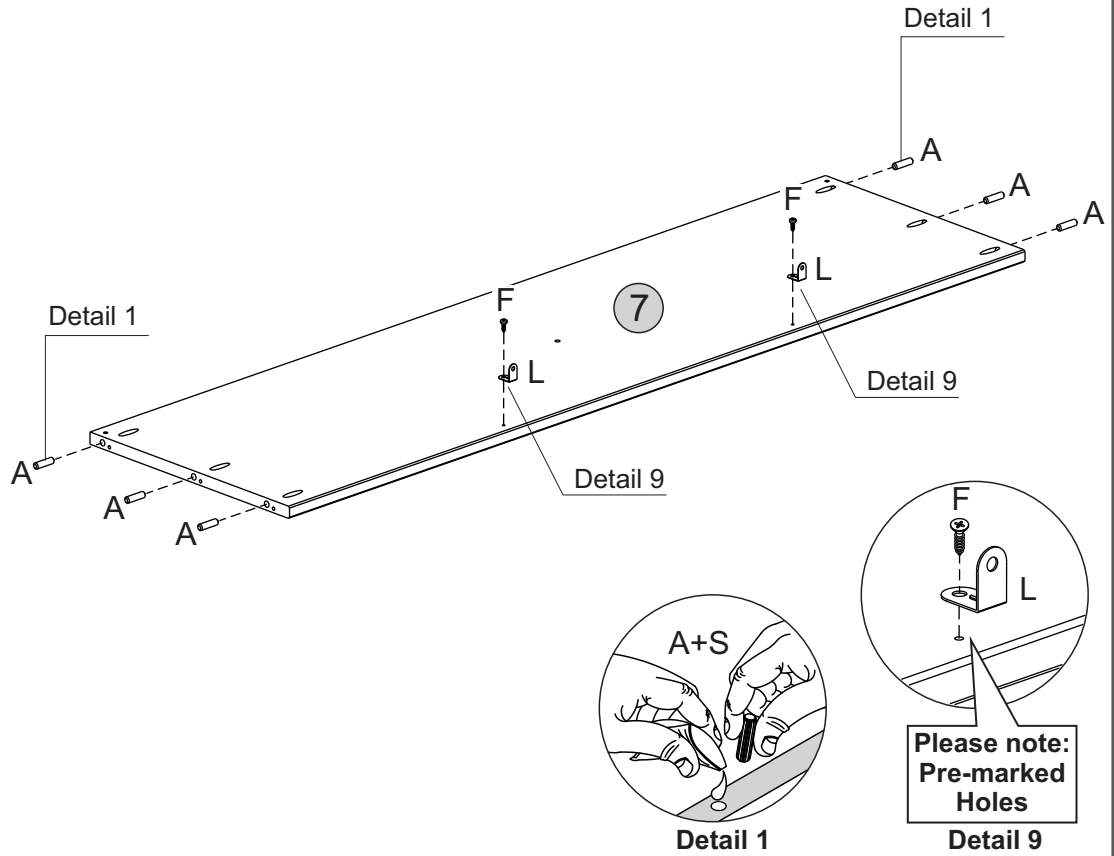
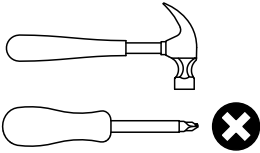



STEP 8

PARTS REQUIRED

10 - DRAWER RUNNER	x2
--------------------	----

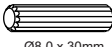
HARDWARE REQUIRED

A		04
Ø8,0 x 30mm		

S		01
Glue		

TOOLS REQUIRED

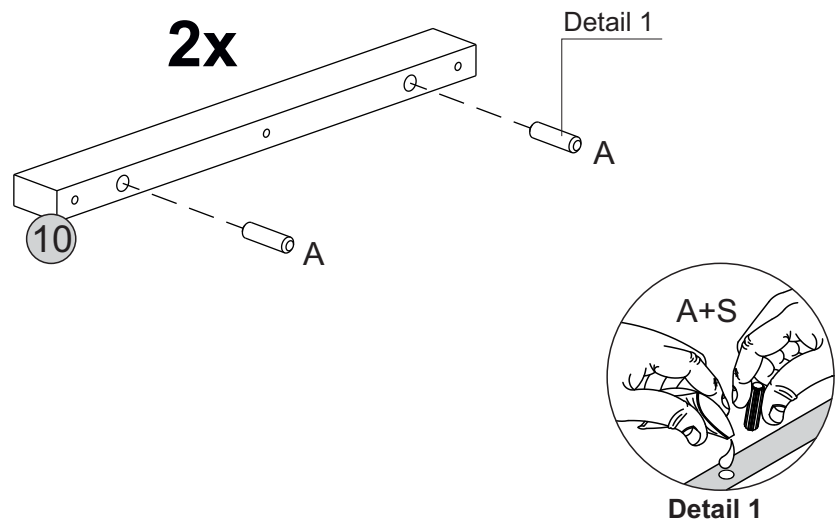
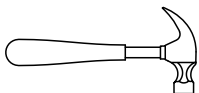



STEP 9

PARTS REQUIRED

20 - CENTER RUNNER	x2
22 - CENTER RUNNER SUPPORT	x2

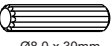
HARDWARE REQUIRED

A		12
Ø8,0 x 30mm		
S		01
Glue		

TOOLS REQUIRED

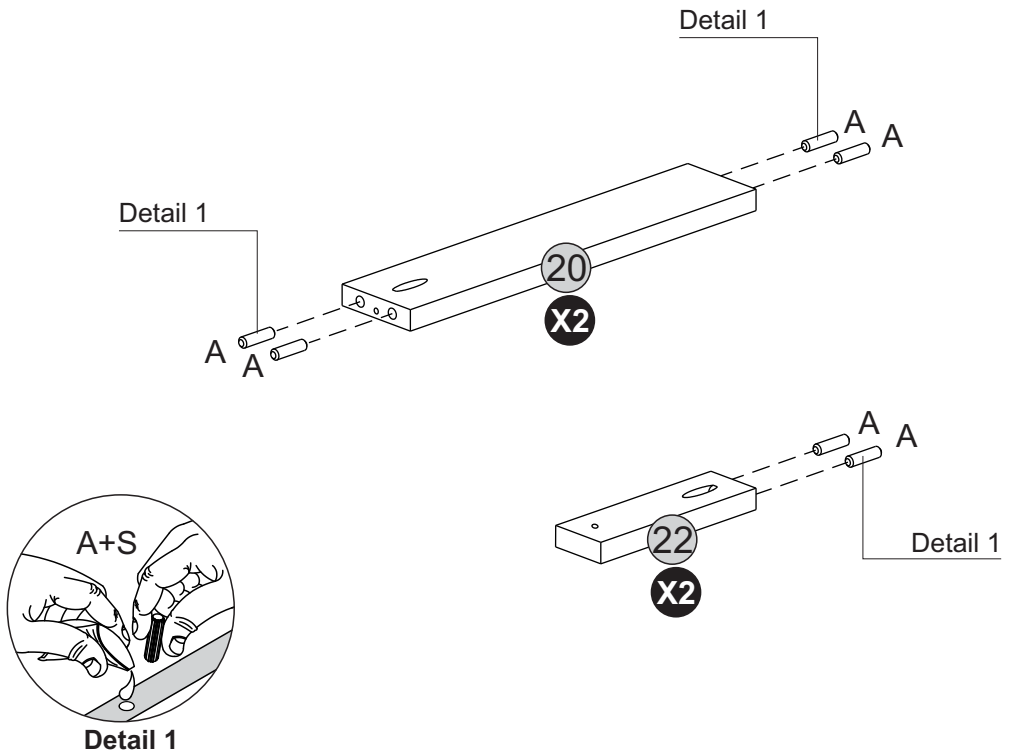
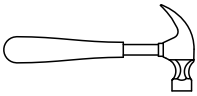

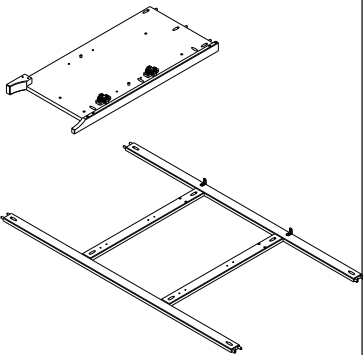

STEP 10

PARTS REQUIRED

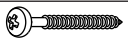

HARDWARE REQUIRED

B		02
Ø3,5 x 30mm		
S		01
Glue		

TOOLS REQUIRED

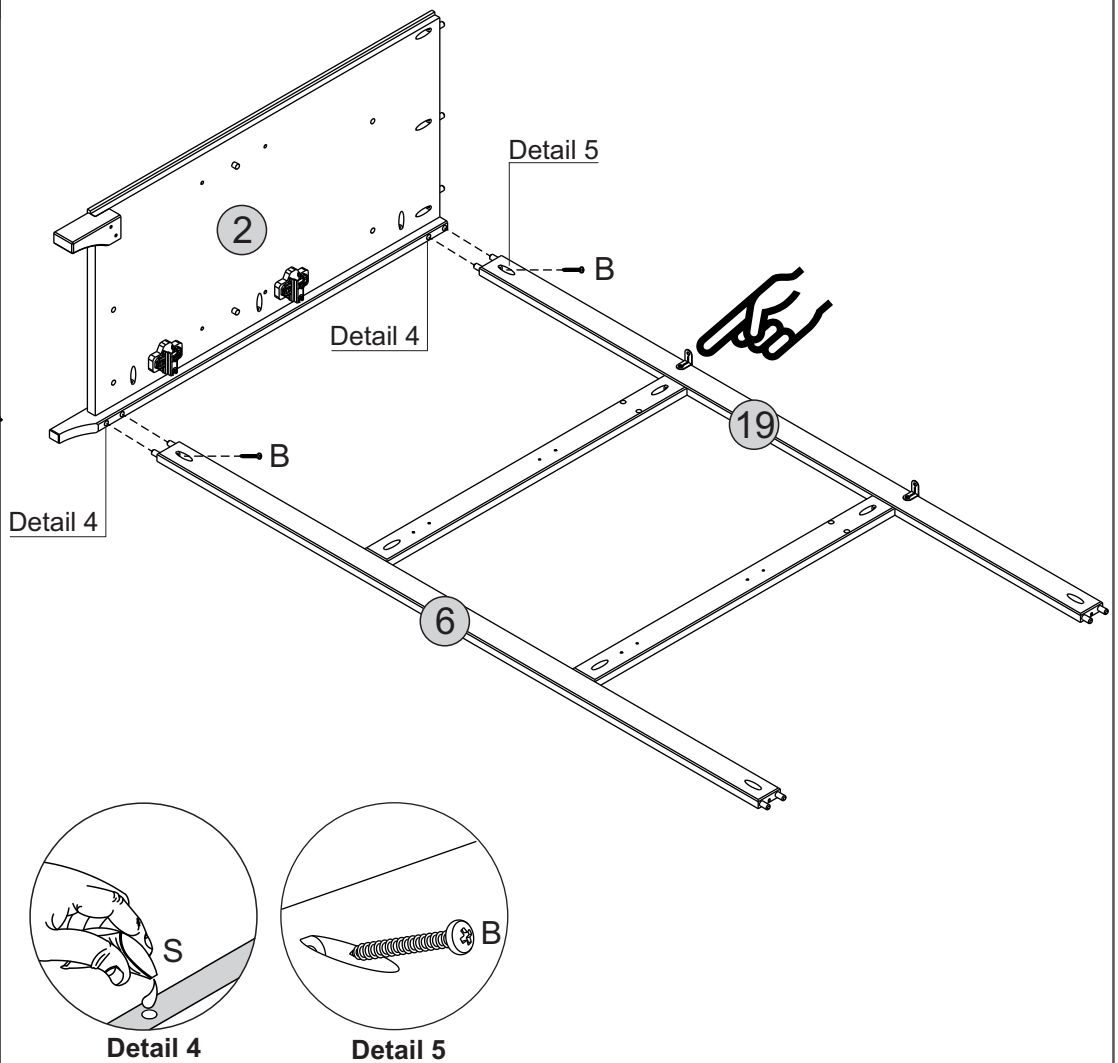
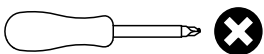

STEP 11

PARTS REQUIRED

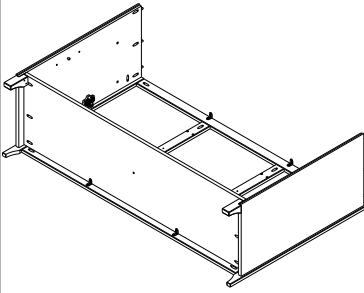

HARDWARE REQUIRED

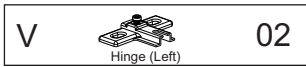
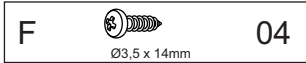

TOOLS REQUIRED

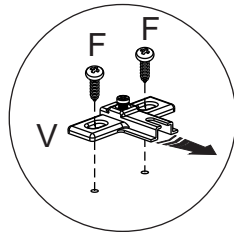
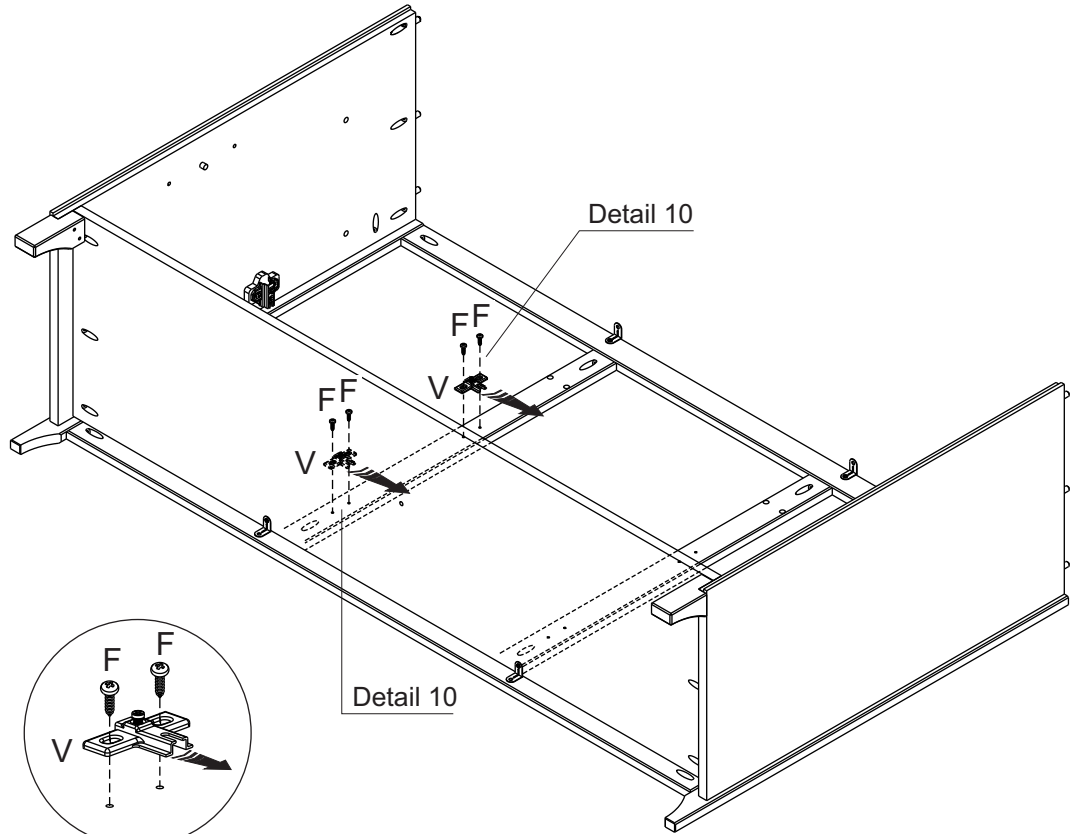
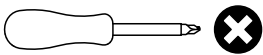

Detail 10

STEP 12

PARTS REQUIRED

1 - TOP PANEL x1

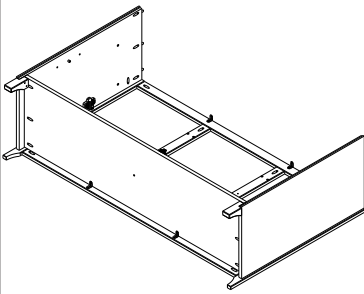

HARDWARE REQUIRED

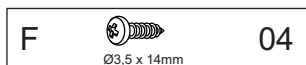
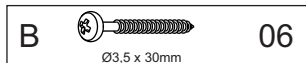

TOOLS REQUIRED

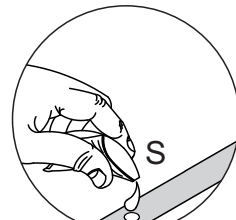
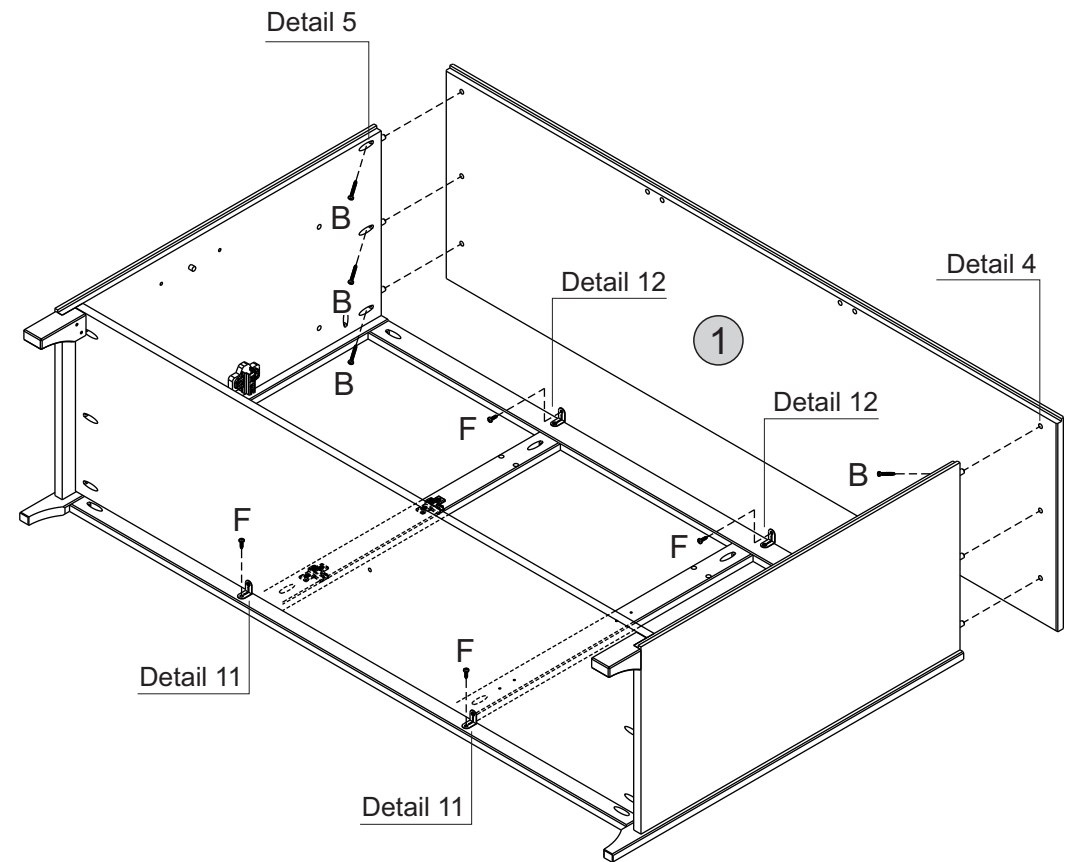
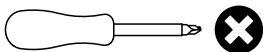

Detail 4

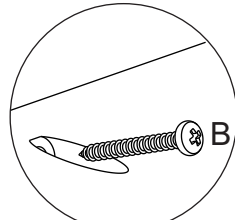

Detail 5

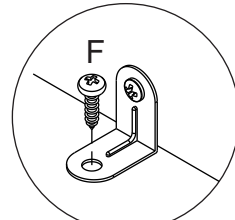

Detail 11

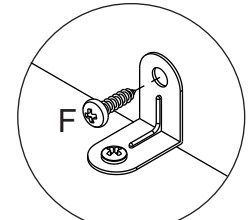

Detail 12

STEP 13

PARTS REQUIRED

7 - BASE x1

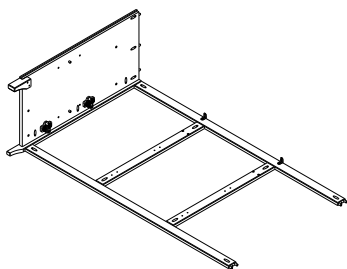

HARDWARE REQUIRED

B  03
Ø3,5 x 30mm

S  01
Glue

TOOLS REQUIRED

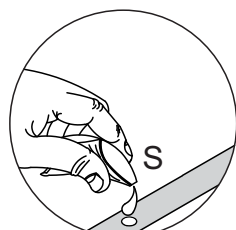
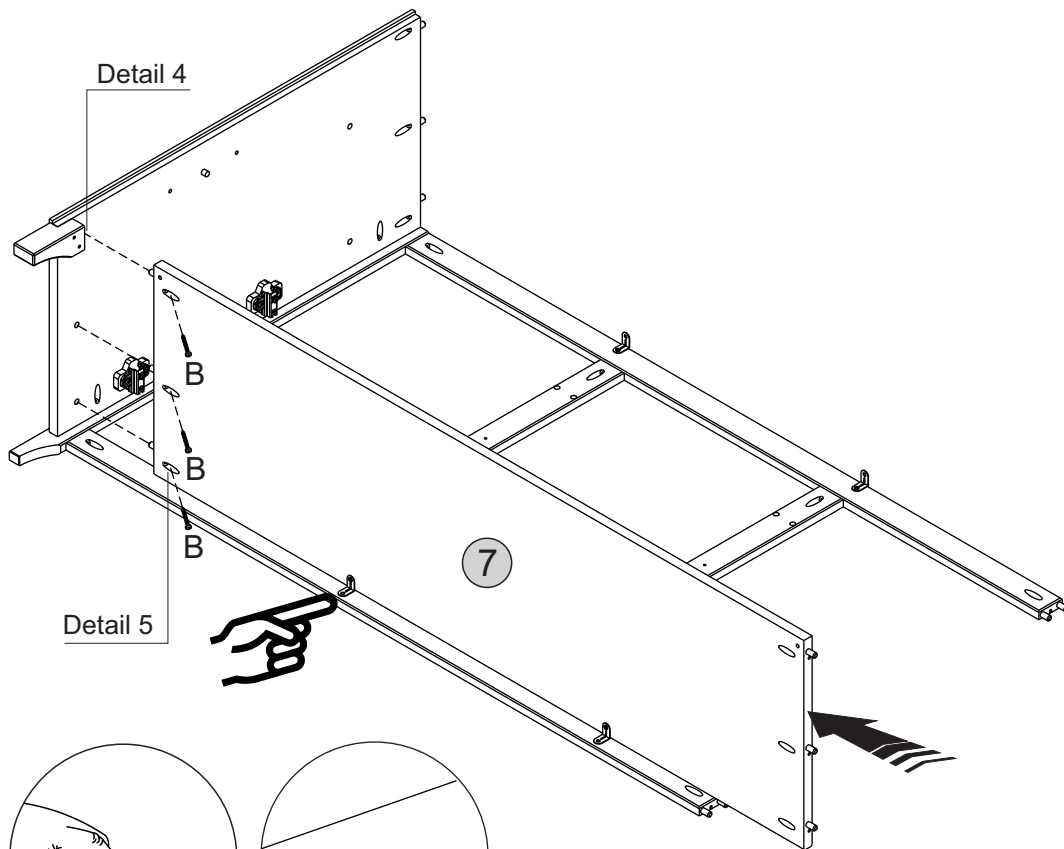
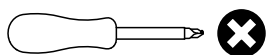

Detail 4

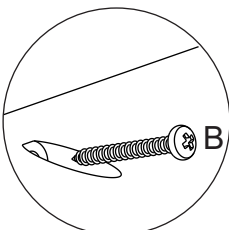

Detail 5

STEP 14

PARTS REQUIRED

4 - LEFT SIDE PANEL x1

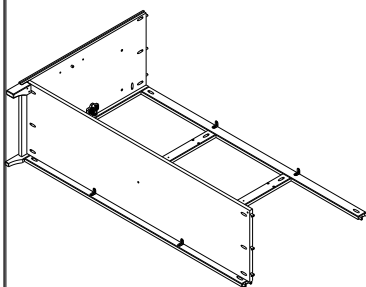

HARDWARE REQUIRED

B  05
Ø3,5 x 30mm

S  01
Glue

TOOLS REQUIRED

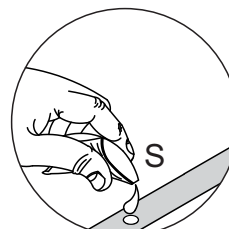
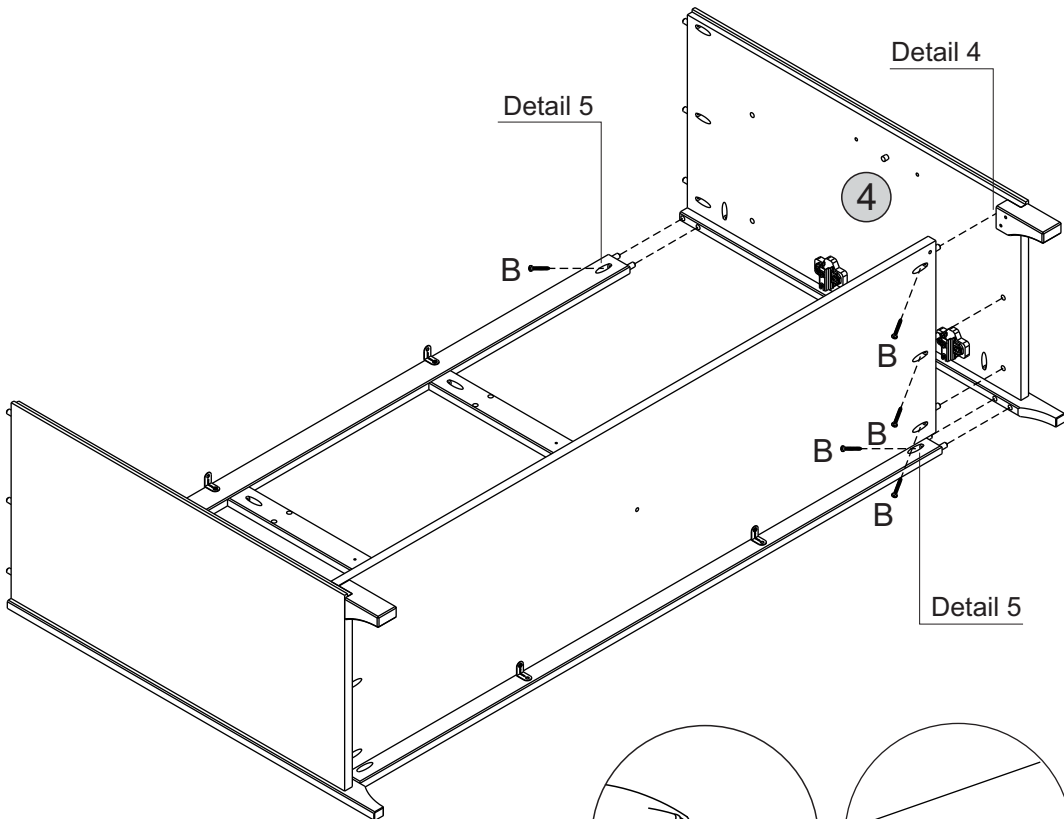
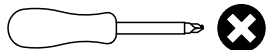

Detail 4

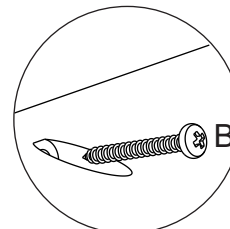

Detail 5

STEP 15

PARTS REQUIRED

10 - DRAWER RUNNER x2

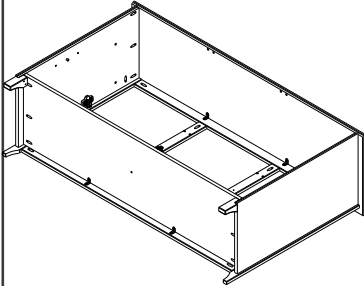

HARDWARE REQUIRED

B  06
Ø3,5 x 30mm

S  01
Glue

TOOLS REQUIRED

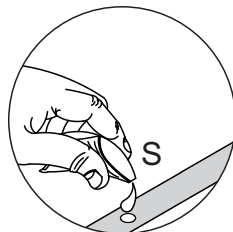
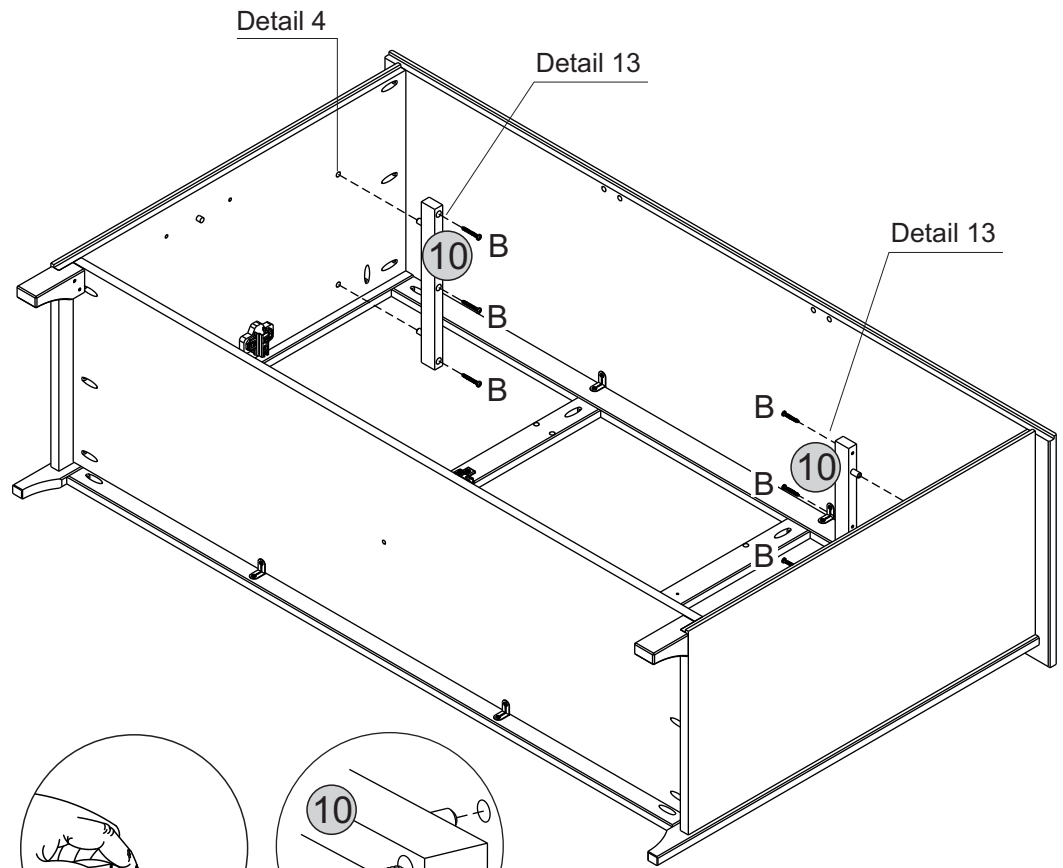
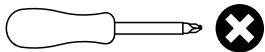

Detail 4

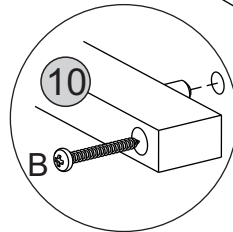

Detail 13

STEP 16

PARTS REQUIRED

17 - CENTER FOOT x1

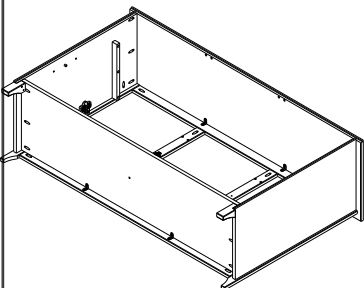

HARDWARE REQUIRED

C  02
Ø4,0 x 35mm

U  01
Ø6,0 x 60mm

TOOLS REQUIRED

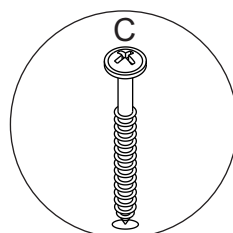
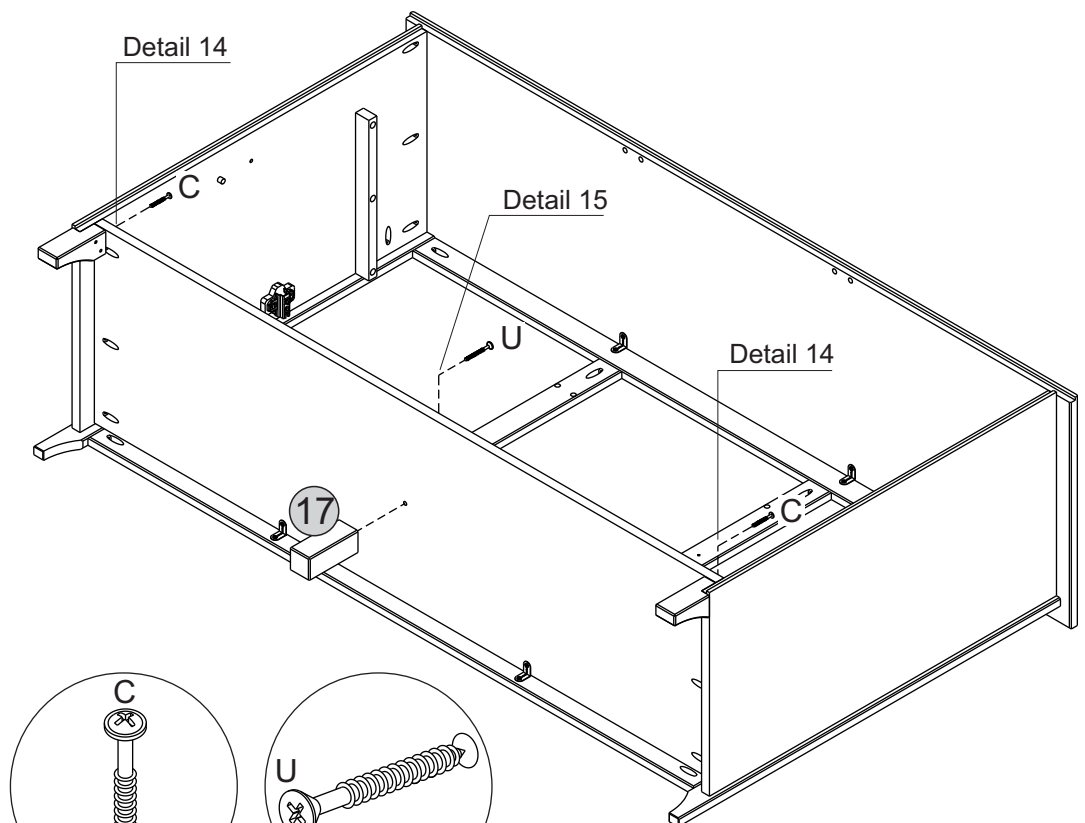

Detail 14

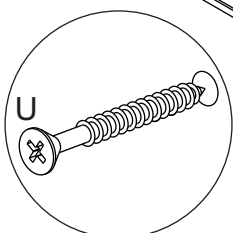

Detail 15

STEP 17

PARTS REQUIRED

20 - CENTER RUNNER x2

22 - CENTER RUNNER SUPPORT x2

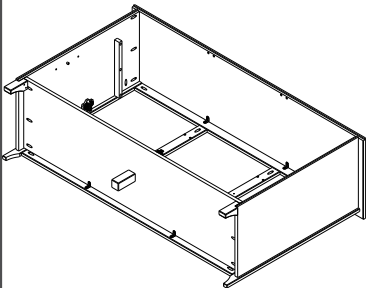

HARDWARE REQUIRED

B  06
Ø3,5 x 30mm

S  01
Glue

TOOLS REQUIRED

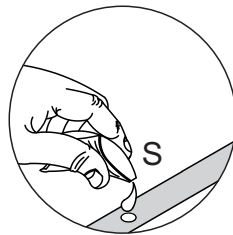
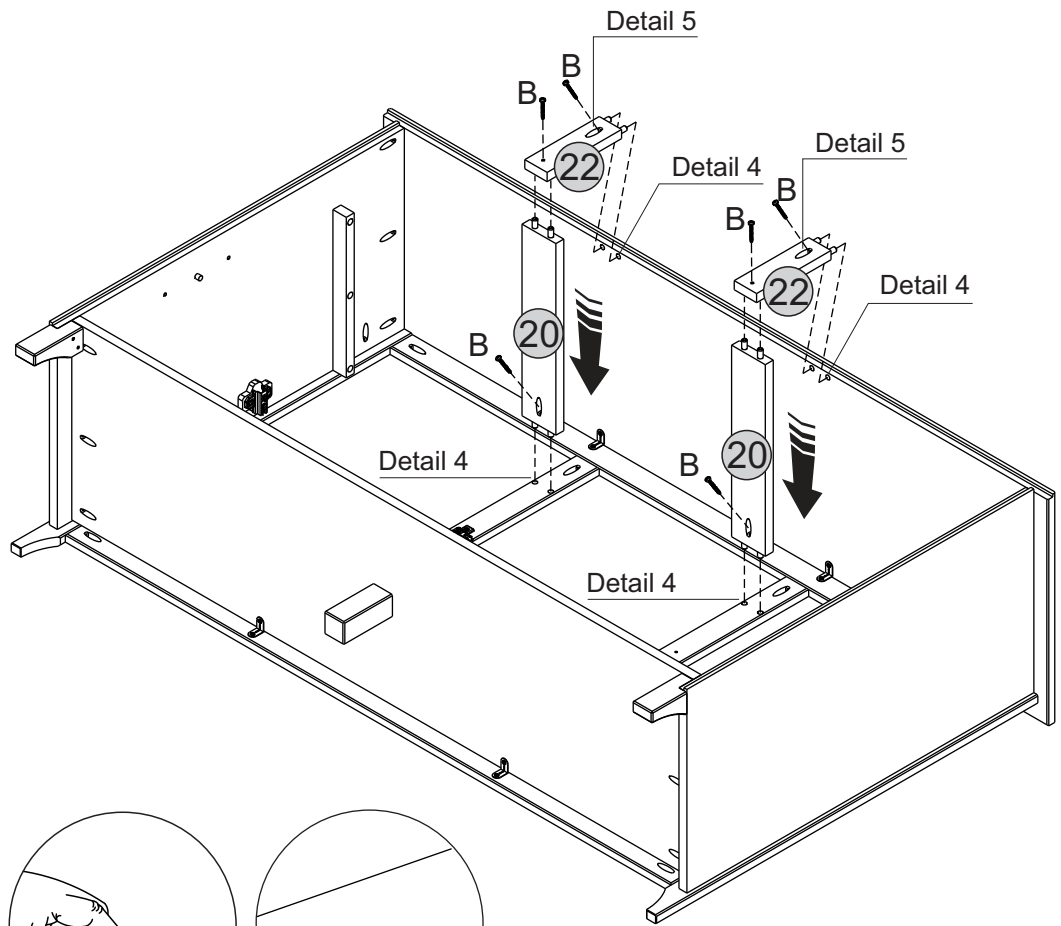
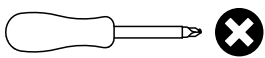

Detail 4

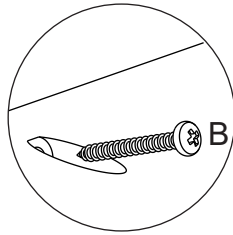

Detail 5

STEP 18

PARTS REQUIRED

20 - DRAWER RUNNER NARROW x4

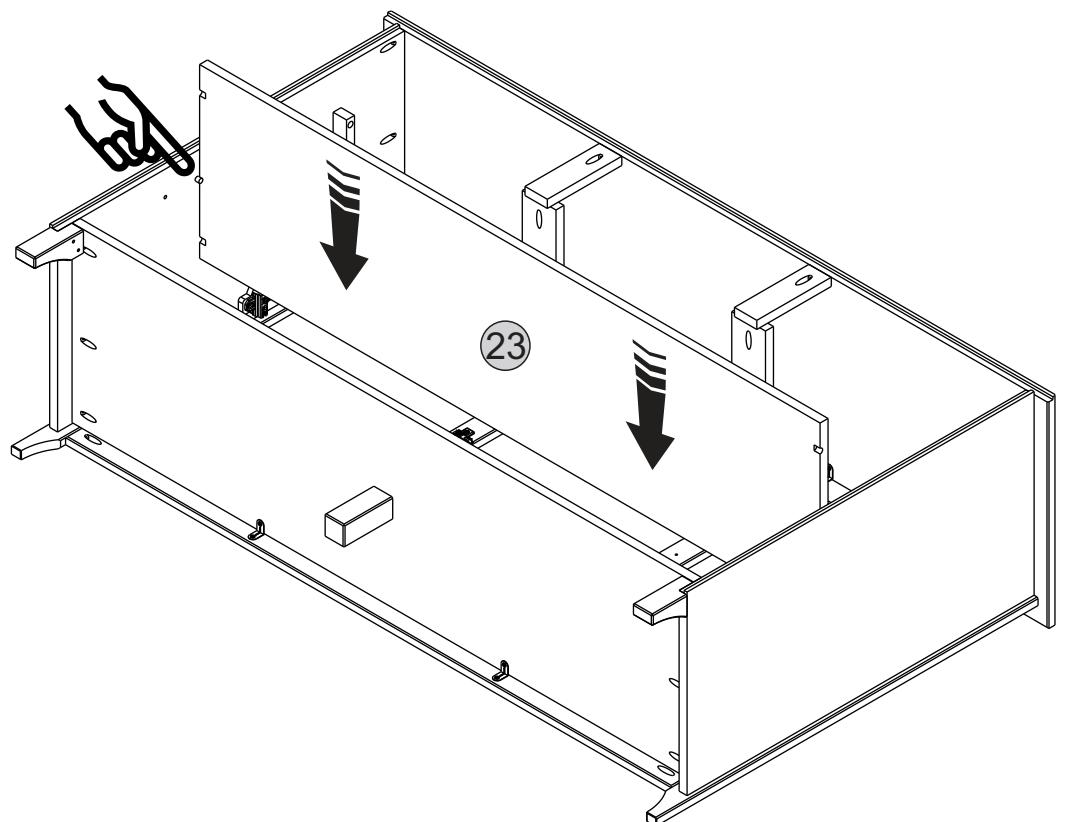
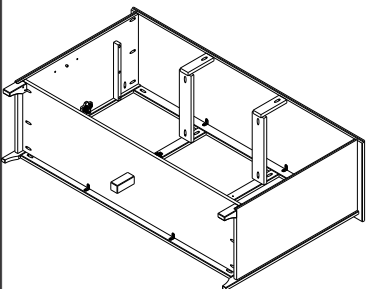

STEP 19

PARTS REQUIRED

11 - BACK PANEL x2

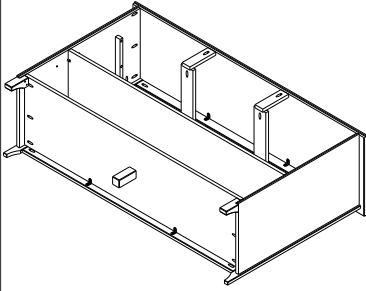

HARDWARE REQUIRED

K  30

P  01
Back Panel Strip

TOOLS REQUIRED

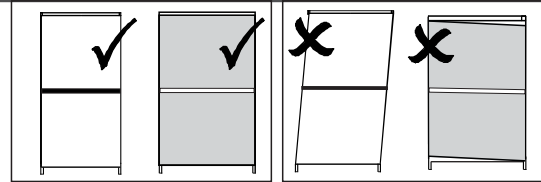
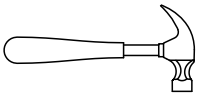

* For your future reference
Order Number should be here

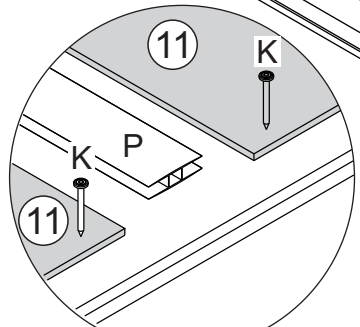
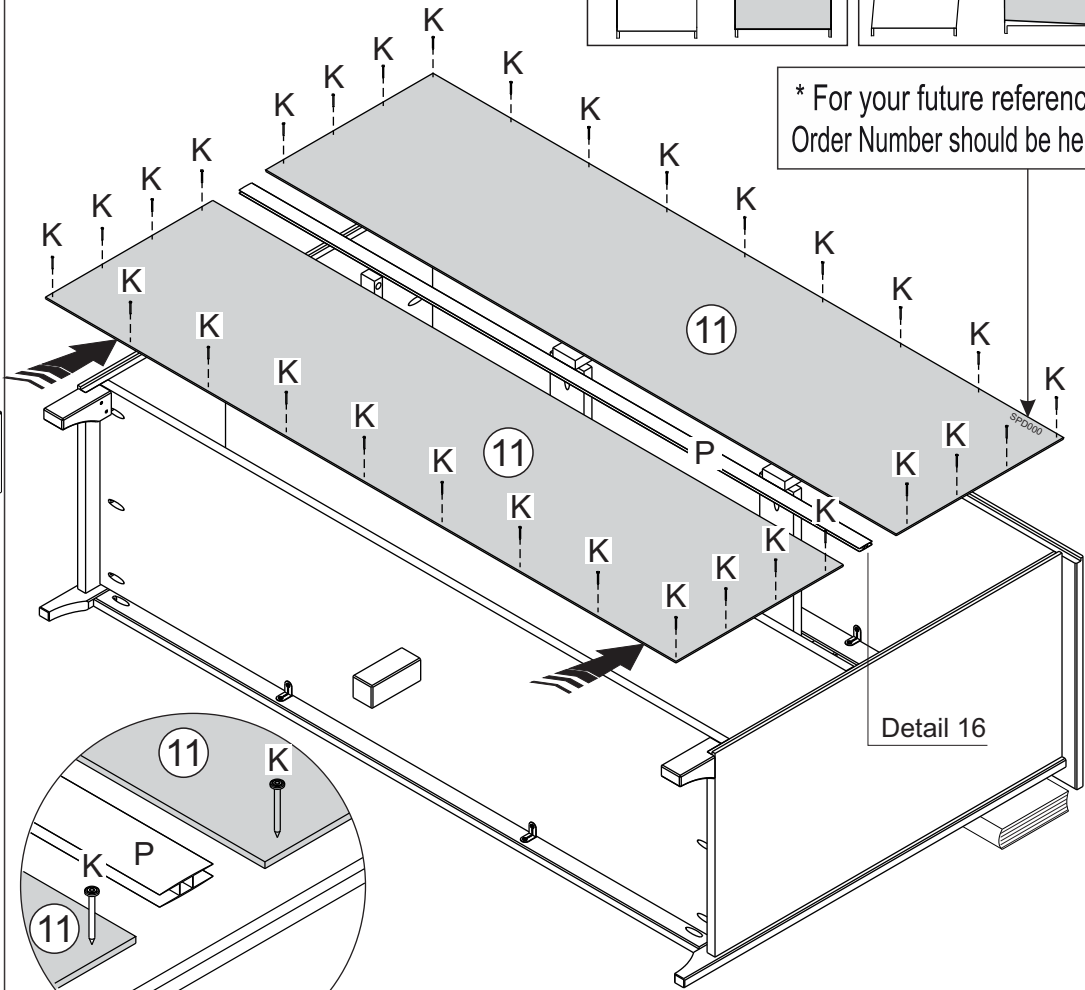

Detail 16

STEP 20

PARTS REQUIRED

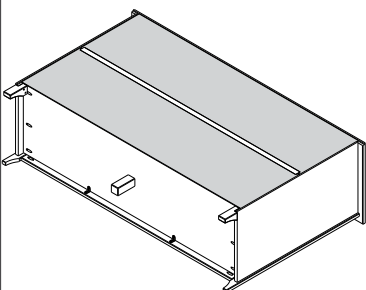

HARDWARE REQUIRED

TOOLS REQUIRED

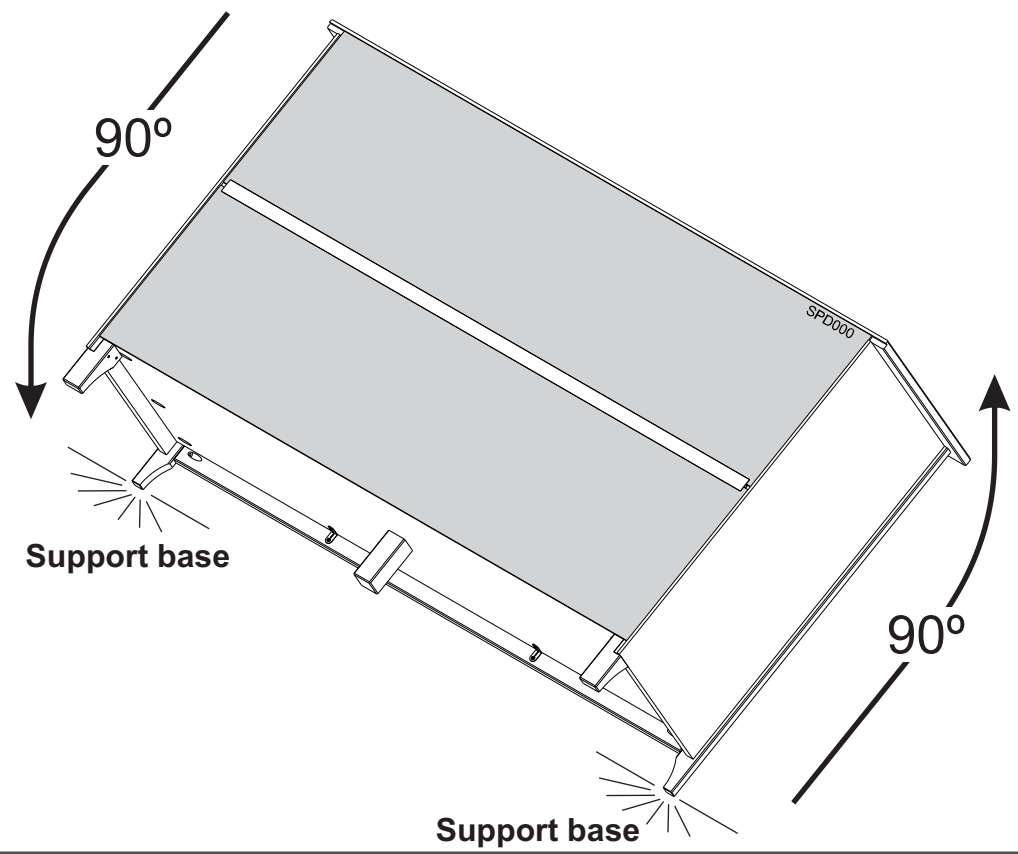

STEP 21

PARTS REQUIRED

13 - RIGHT DRAWER SIDE x3

14 - LEFT DRAWER SIDE x3

HARDWARE REQUIRED

A  12
Ø8,0 x 30mm

S  01
Glue

TOOLS REQUIRED

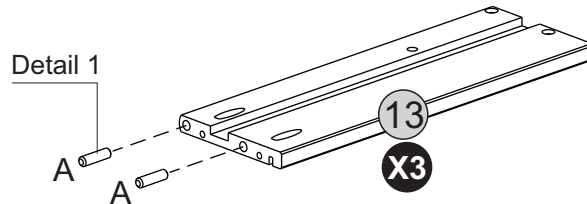
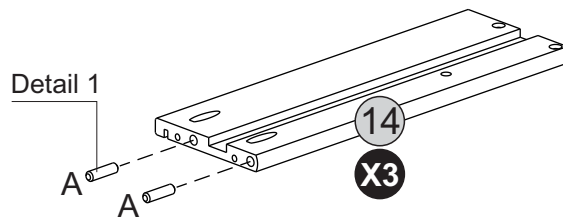
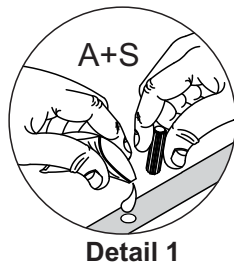
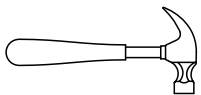

STEP 22

PARTS REQUIRED

12 - DRAWER FRONT x3

13 - RIGHT DRAWER SIDE x3

14 - LEFT DRAWER SIDE x3

HARDWARE REQUIRED

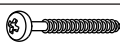
B  12
Ø3,5 x 30mm

S  01
Glue

TOOLS REQUIRED

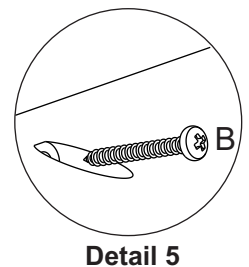
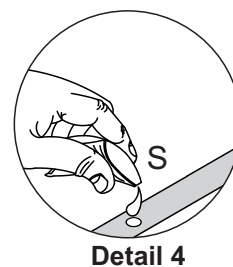
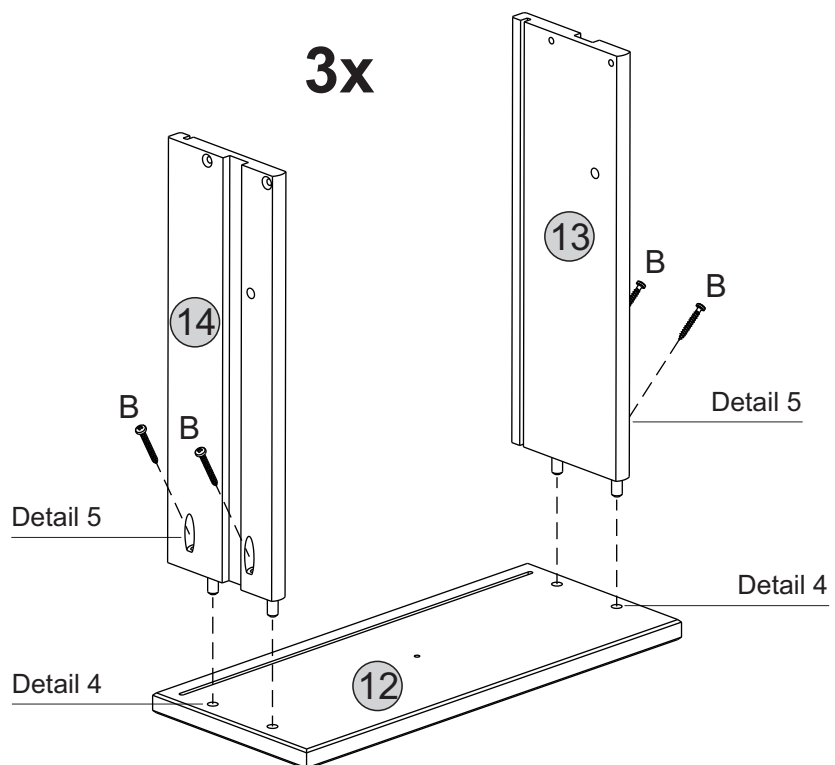
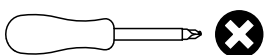

STEP 23

PARTS REQUIRED

15 - DRAWER BOTTOM x3

16 - DRAWER BACK PANEL x3

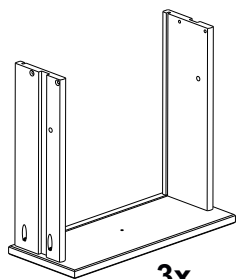

3x

HARDWARE REQUIRED

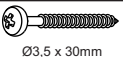
B  12
Ø3,5 x 30mm

TOOLS REQUIRED

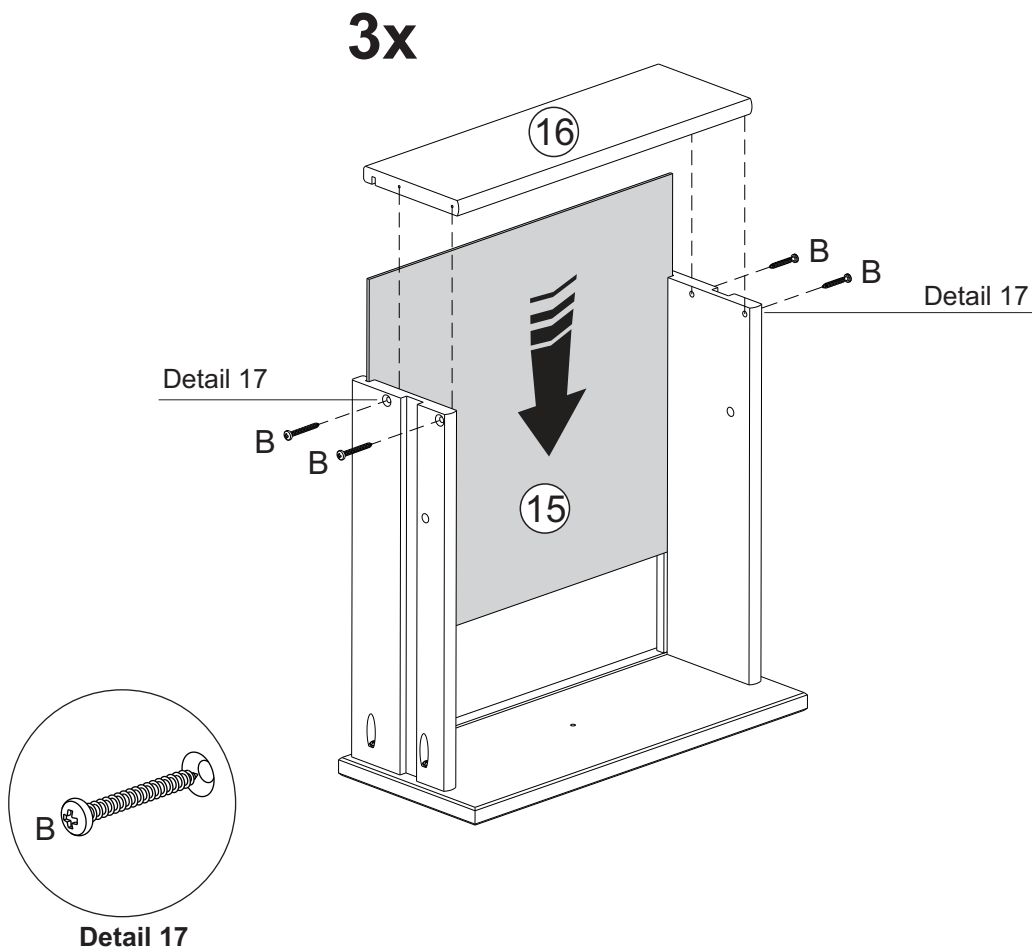
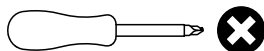

STEP 24

PARTS REQUIRED

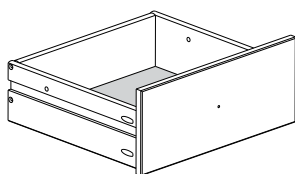

3x

HARDWARE REQUIRED

I  03
Metal Knob

J  03
ØM4 x 22mm

TOOLS REQUIRED

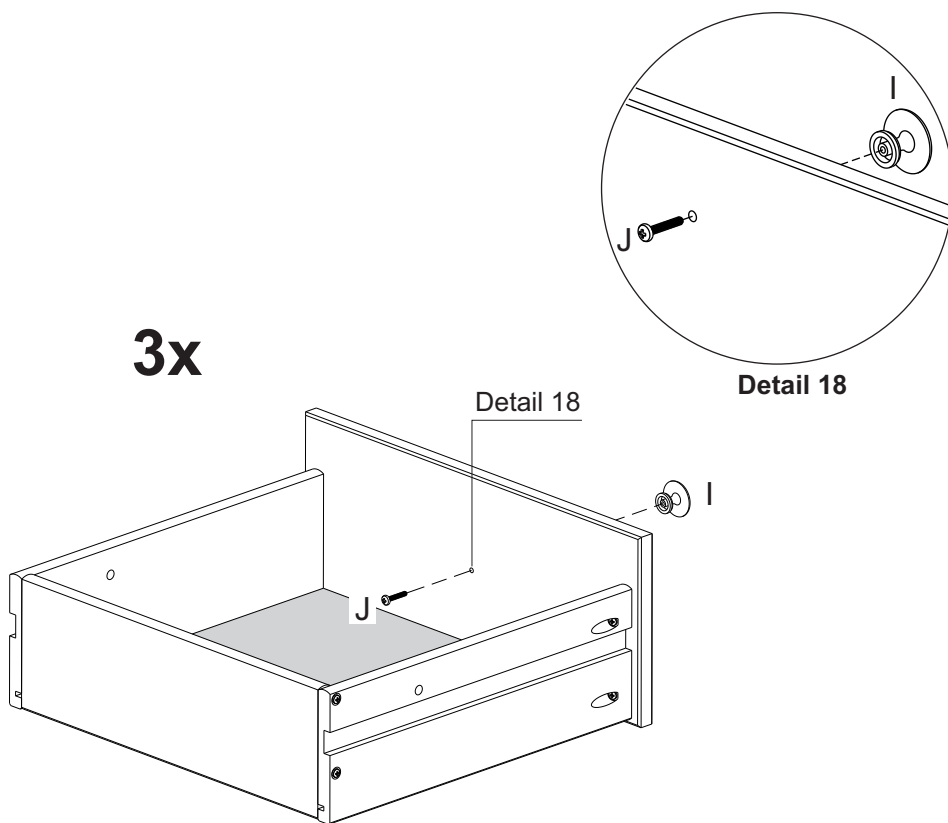
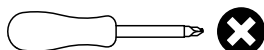

STEP 25

PARTS REQUIRED

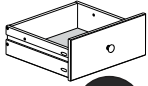
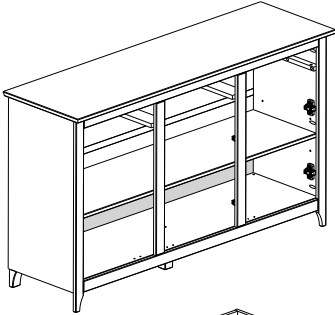

X3

HARDWARE REQUIRED

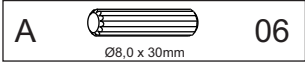

TOOLS REQUIRED

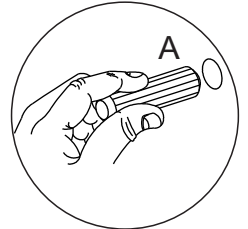
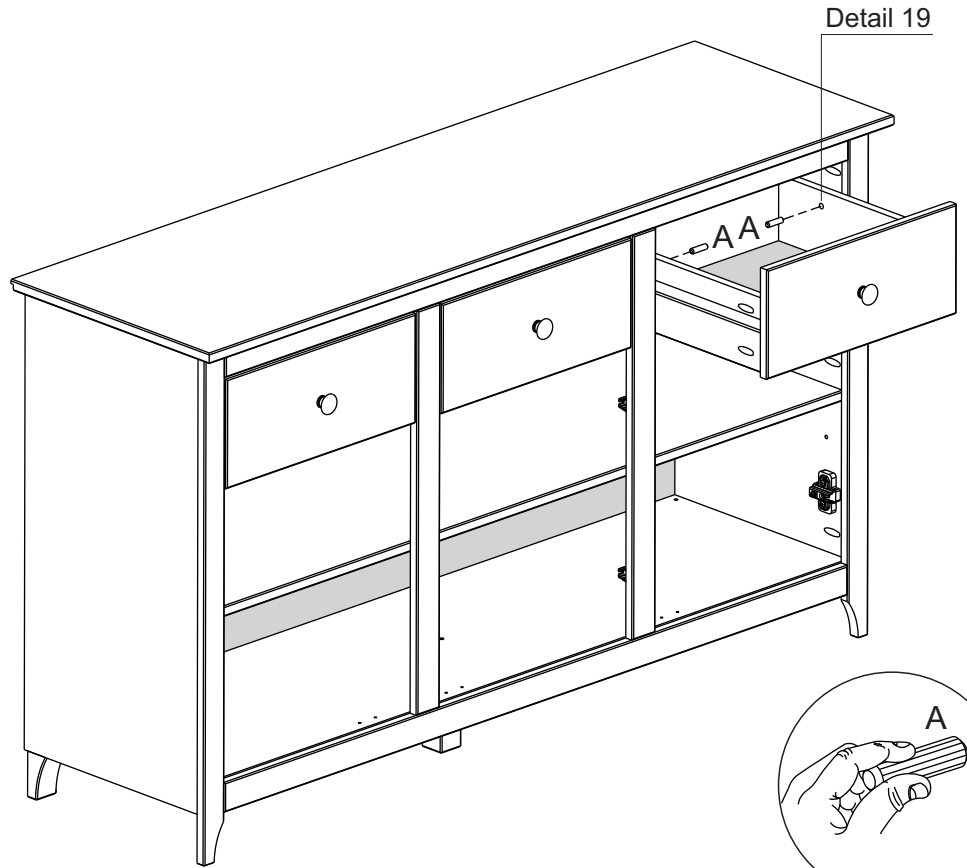
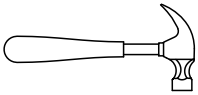

Detail 19

STEP 26

PARTS REQUIRED

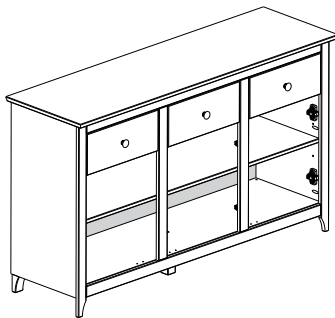

HARDWARE REQUIRED



TOOLS REQUIRED

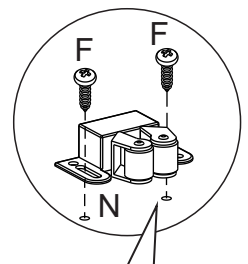
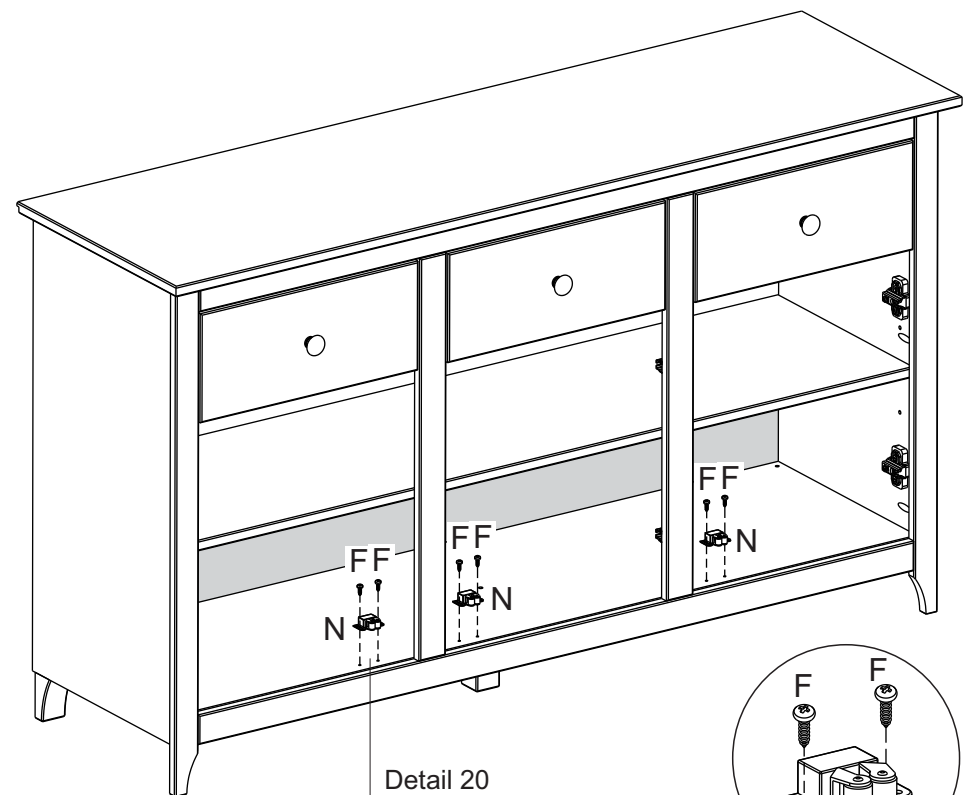
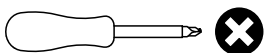

**Please note:
Pre-marked
Holes**

Detail 20

STEP 27

PARTS REQUIRED

21 - DOOR x2

HARDWARE REQUIRED

F  08
Ø3,5 x 14mm

G  04
Hinge (Right)

TOOLS REQUIRED

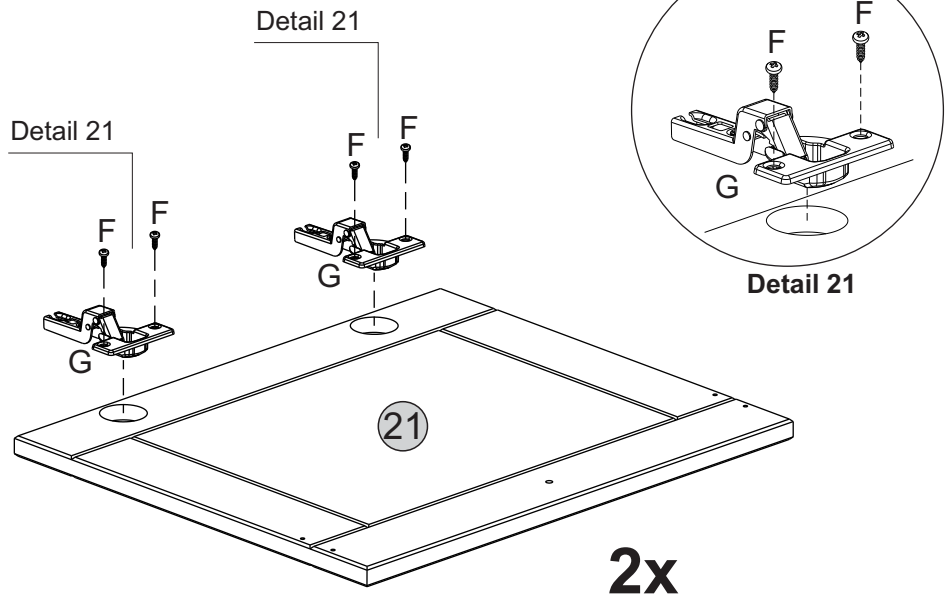
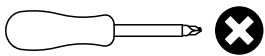

STEP 28

PARTS REQUIRED

21 - DOOR x2

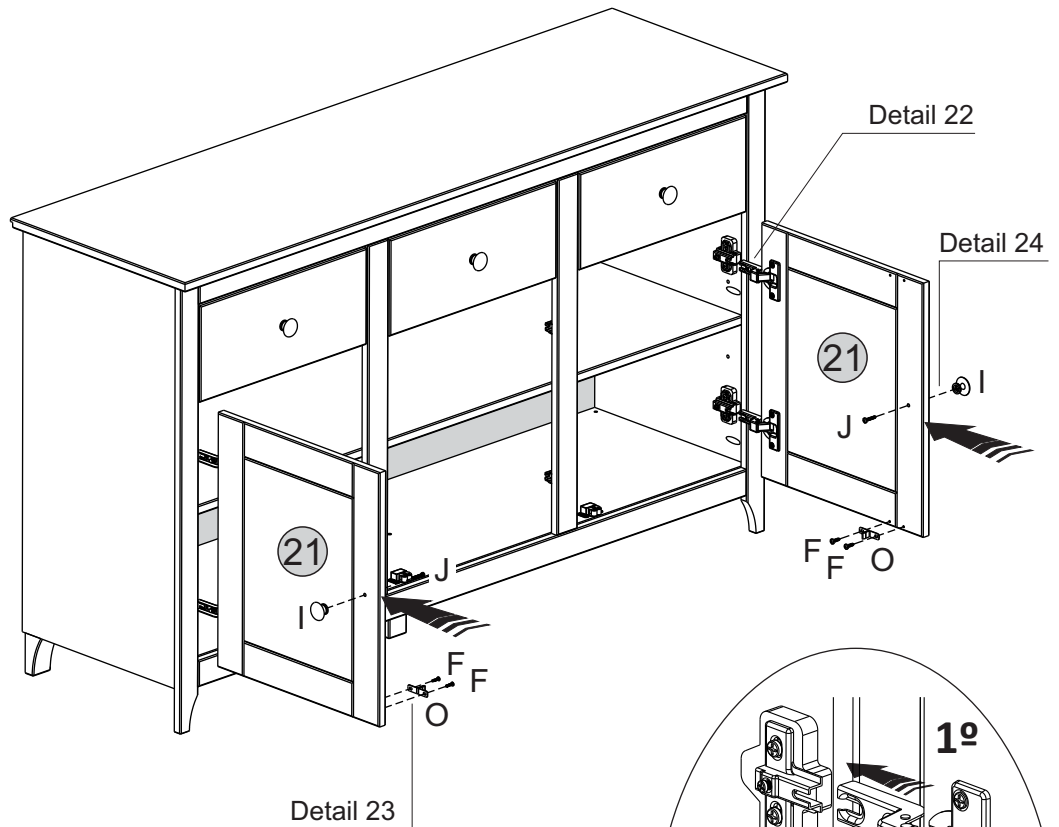
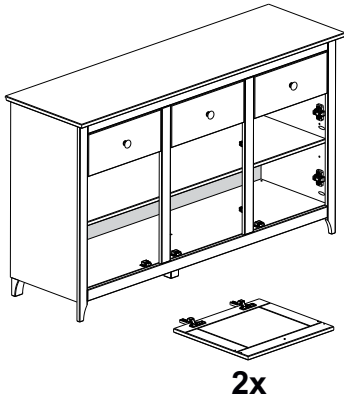

HARDWARE REQUIRED

F  04
Ø3,5 x 14mm

I  02
Metal Knob

J  02
ØM4 x 22mm

O  02
Knocker

TOOLS REQUIRED

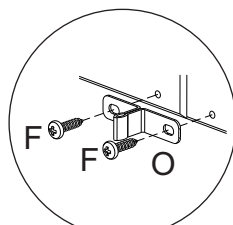
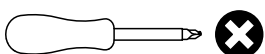

Detail 23

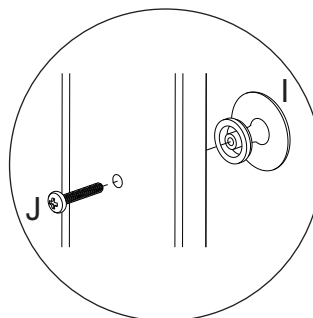

Detail 24

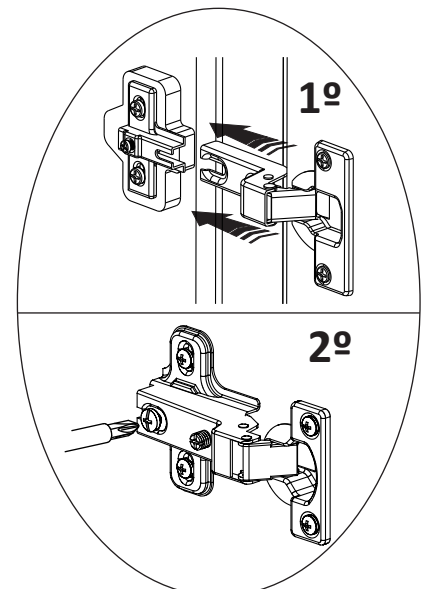

Detail 22

STEP 29

PARTS REQUIRED

21 - DOOR x1

HARDWARE REQUIRED

- D 02
- F 04

TOOLS REQUIRED

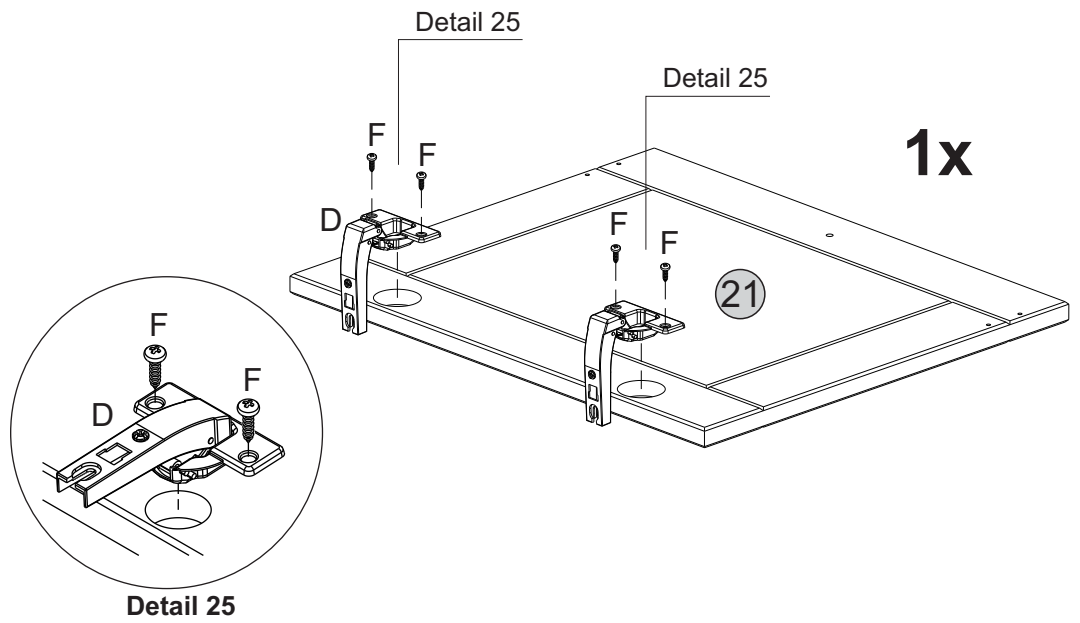
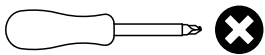

STEP 30

PARTS REQUIRED

21 - DOOR x1

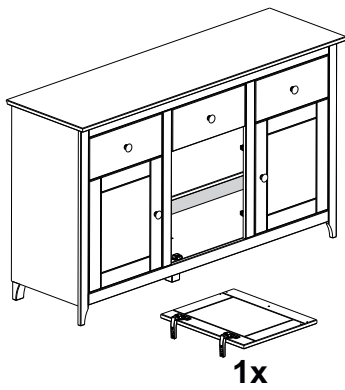

HARDWARE REQUIRED

- F 02
- I 01
- J 01
- O 01

TOOLS REQUIRED

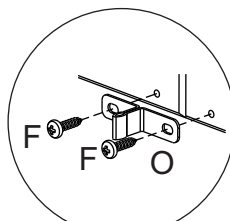
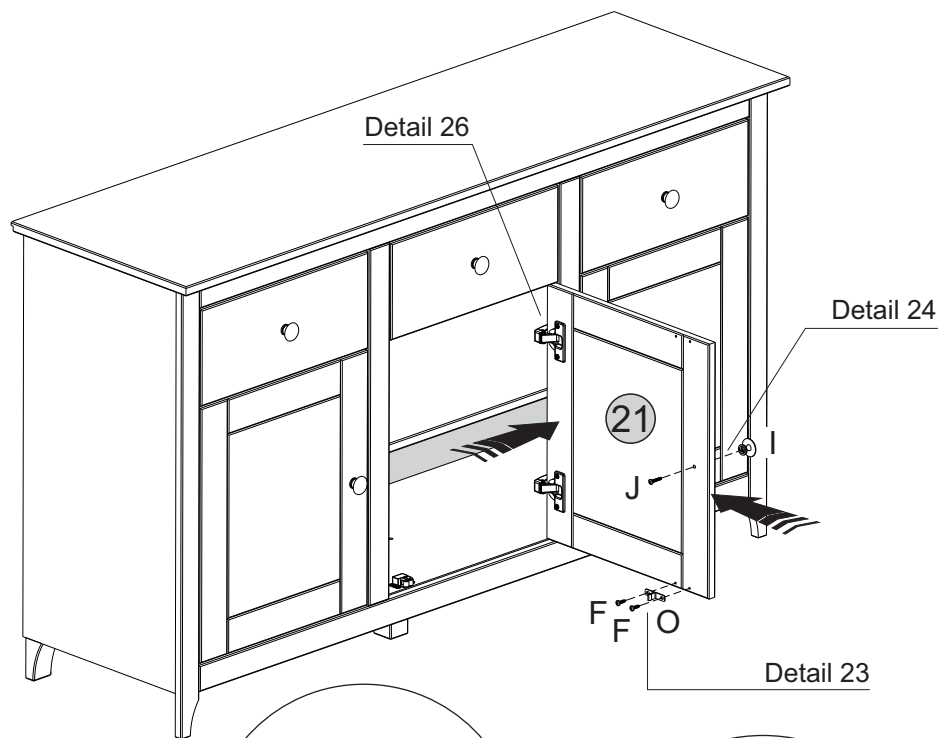
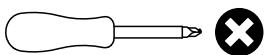

Detail 23

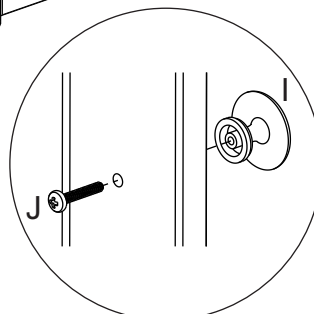

Detail 24

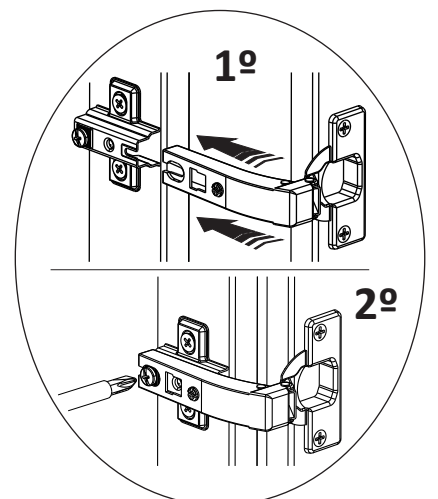

Detail 26

ADJUSTMENTS

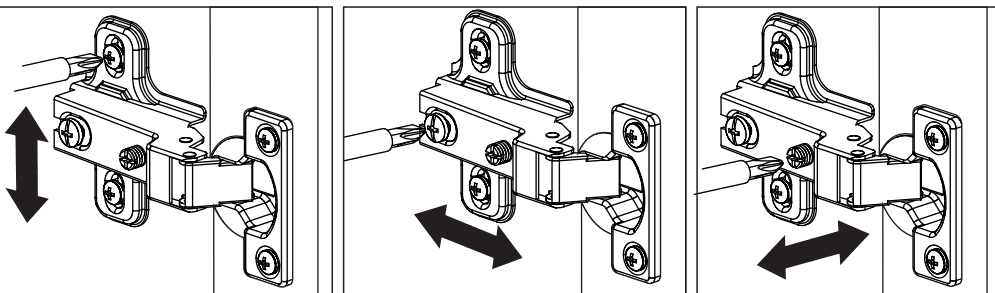





WARNING

Serious or fatal injuries can occur from furniture tipping over. To prevent the furniture from tipping over we recommend that it is permanently fixed to the wall.

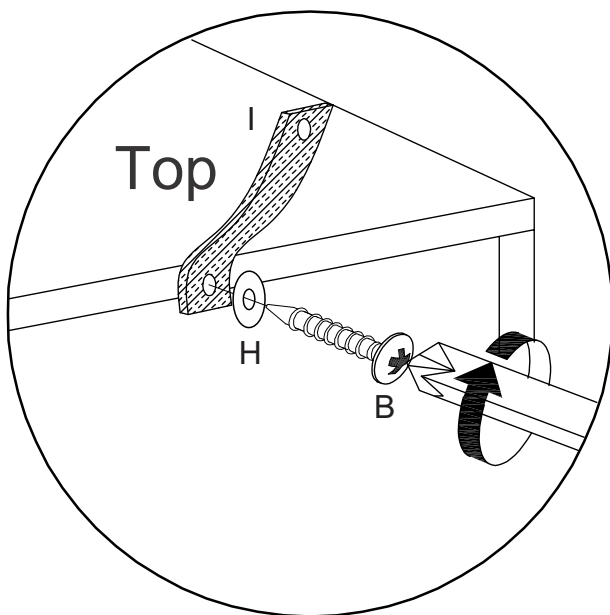
Wall fixings are not supplied with this product as different wall materials require different types of fixing devices.

Please make sure you use fixings suitable for the walls in your home.



B		01
	$\text{Ø}3,5 \times 30\text{mm}$	
H		02
	Washer	
I		01
	Strap	

